

Skarpa kanter bryts $0.5 \times 45^\circ$

Pos nr	Antal	Titel/Benämning, beteckning, material, dimension o d			Artikel nr/referens	
Konstruerad UK	Granskad av PF	Godkänd av - datum PT 201015	Generell tolerans ISO 2768-1f	Standard A4	Vyplacering E	Skala 1:2
Agare		KUNGSMADESKOLAN		Benämning SVARV 2 MÄT 2		Datum 201005
					Ritningsnummer	26

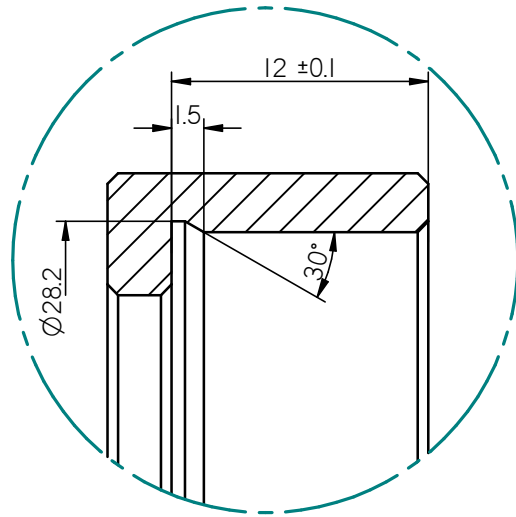

DELFÖRSTÖRING A

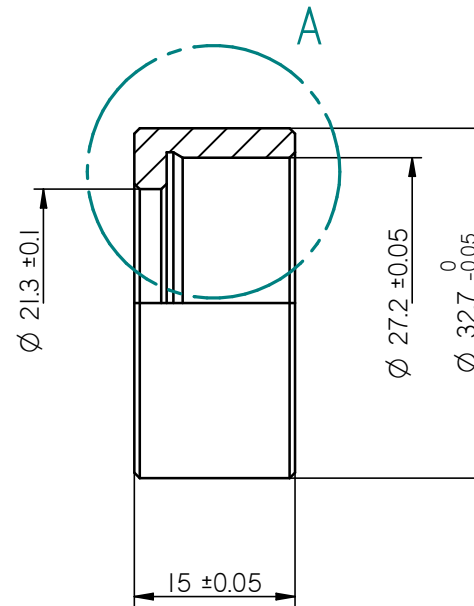

Skarpa kanter bryts $0.5 \times 45^\circ$

Pos nr	Antal	Titel/Benämning, beteckning, material, dimension o d			Artikel nr/referens	
Konstruerad UK	Granskad av PF	Godkänd av - datum PT 201015	Generell tolerans ISO 2768-1f	Standard A4	Vyplacering E	Skala 1:2
Agare				Benämning SVARV 2 MÄT 1		Datum 201005
					Ritningsnummer	28

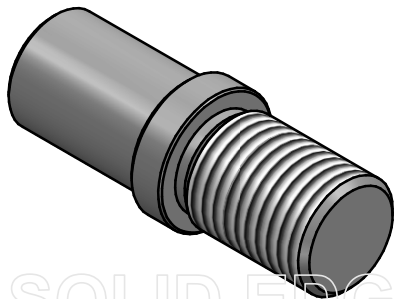
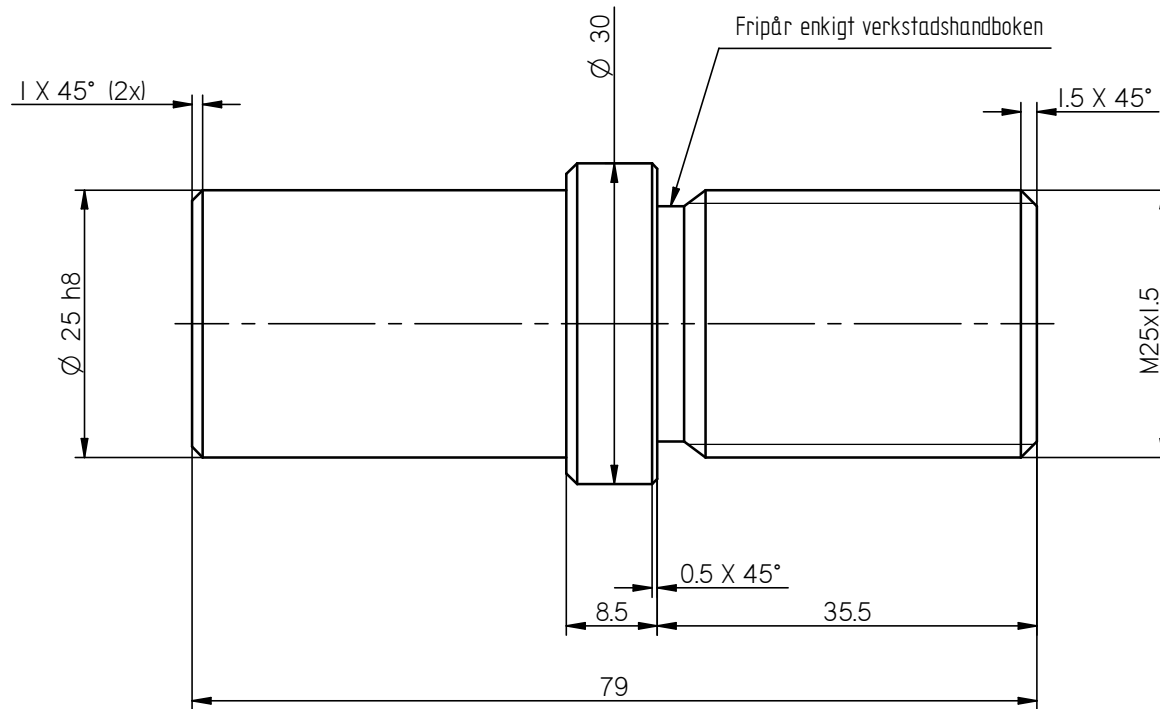

Skarpa kanter bryts 0.5x45°

Pos nr	Antal	Titel/Benämning, beteckning, material, dimension o d			Artikel nr/referens	
Konstruerad UK	Granskad av PF	Godkänd av - datum PT 201015	Generell tolerans ISO 2768-1f	Standard A4	Vyplacering E	Skala 1:2
Agare		KUNGSMADESKOLAN		Benämning SVARV 2		Datum 201005
					Ritningsnummer	20

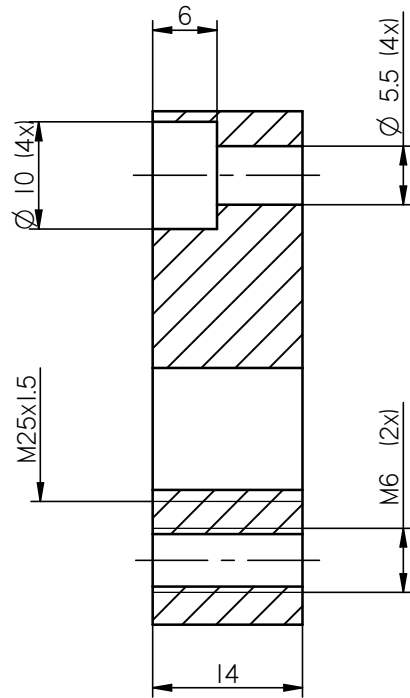

SNITT A-A

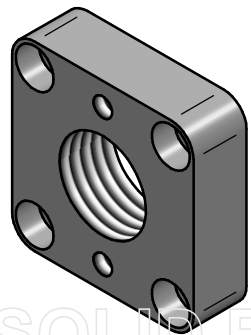
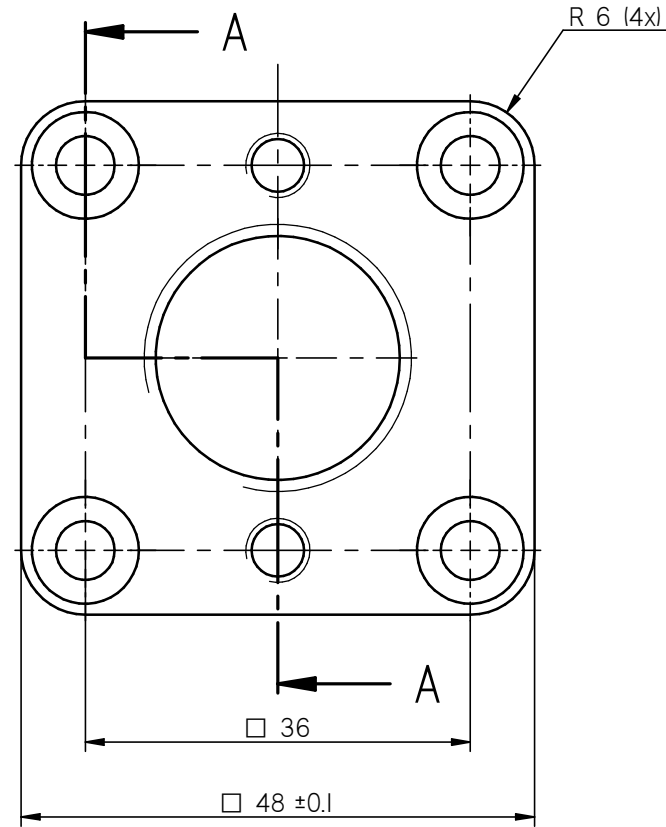

Skarpa kanter bryts 0.5x45°

Pos nr	Antal	Titel/Benämning, beteckning, material, dimension o d			Artikel nr/referens	
Konstruerad UK	Granskad av PF	Godkänd av - datum PT 201015	Generell tolerans ISO 2768-1f	Standard A4	Vyplacering E	Skala 1:2
Agare		Benämning		Datum 201005		
KUNGSMADESKOLAN		FRÄS 2		Ritningsnummer 31		

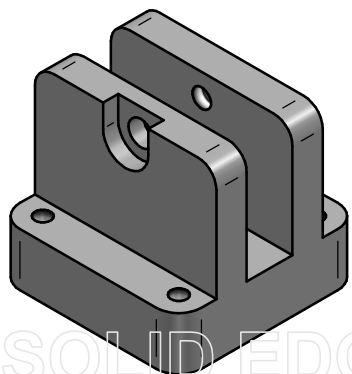
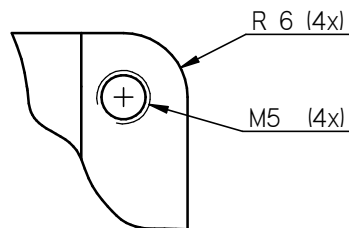
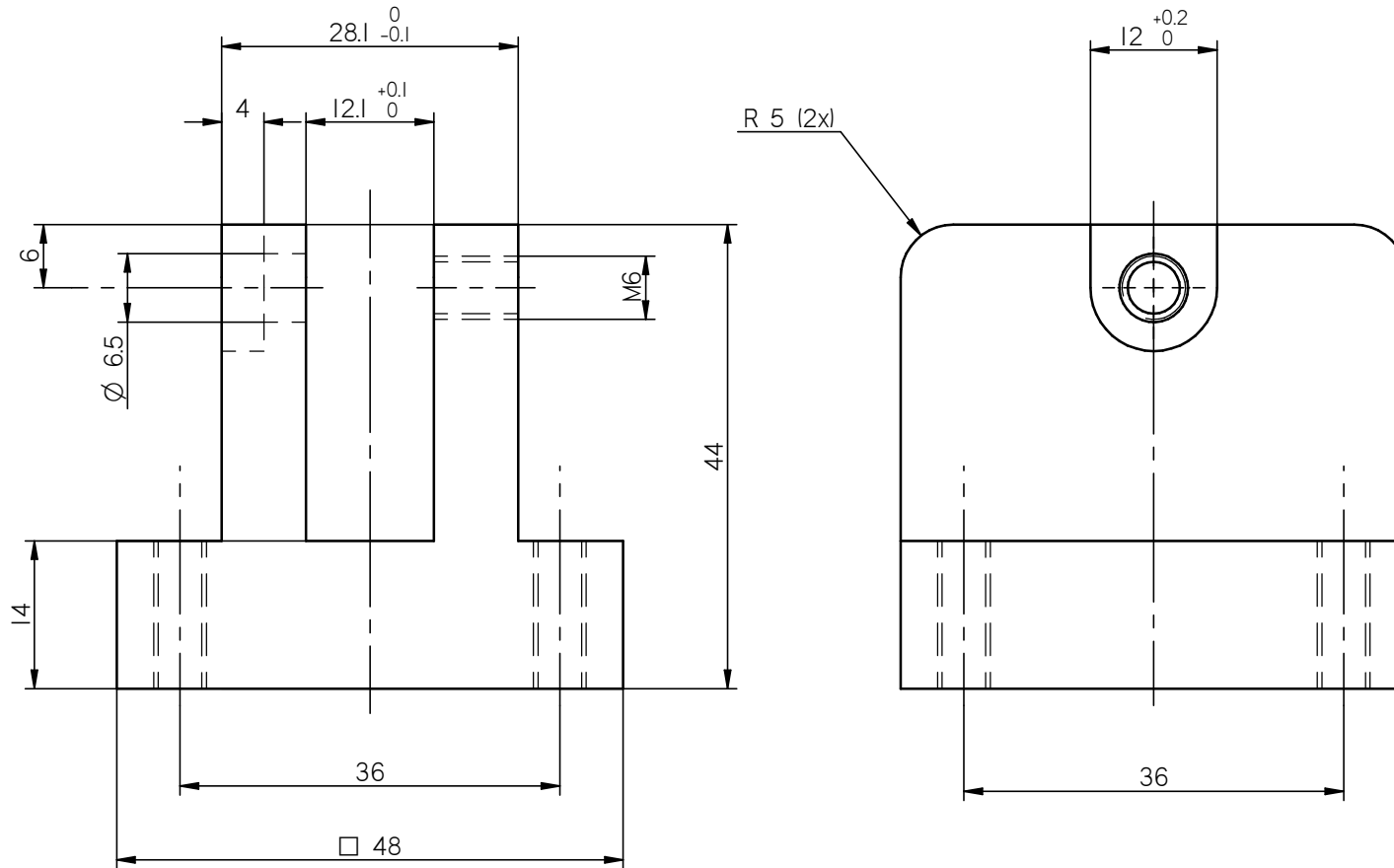

Skarpa kanter bryts 0.5x45°

Pos nr	Antal	Titel/Benämning, beteckning, material, dimension o d			Artikel nr/referens	
Konstruerad UK	Granskad av PF	Godkänd av - datum PT 201015	Generell tolerans ISO 2768-1f	Standard A4	Vyplacering E	Skala 1:2
Agare		Benämning		Datum 201005		
KUNGSMADESKOLAN		FRÄS 2		Ritningsnummer 30		

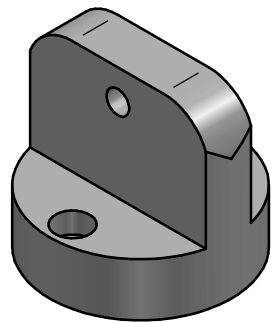
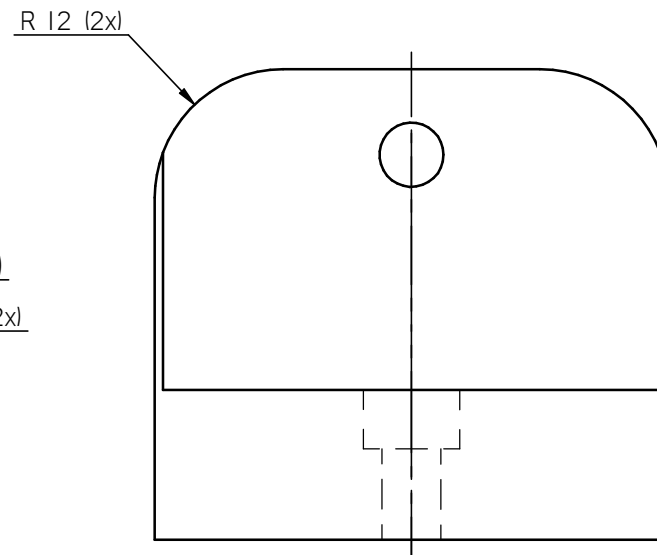
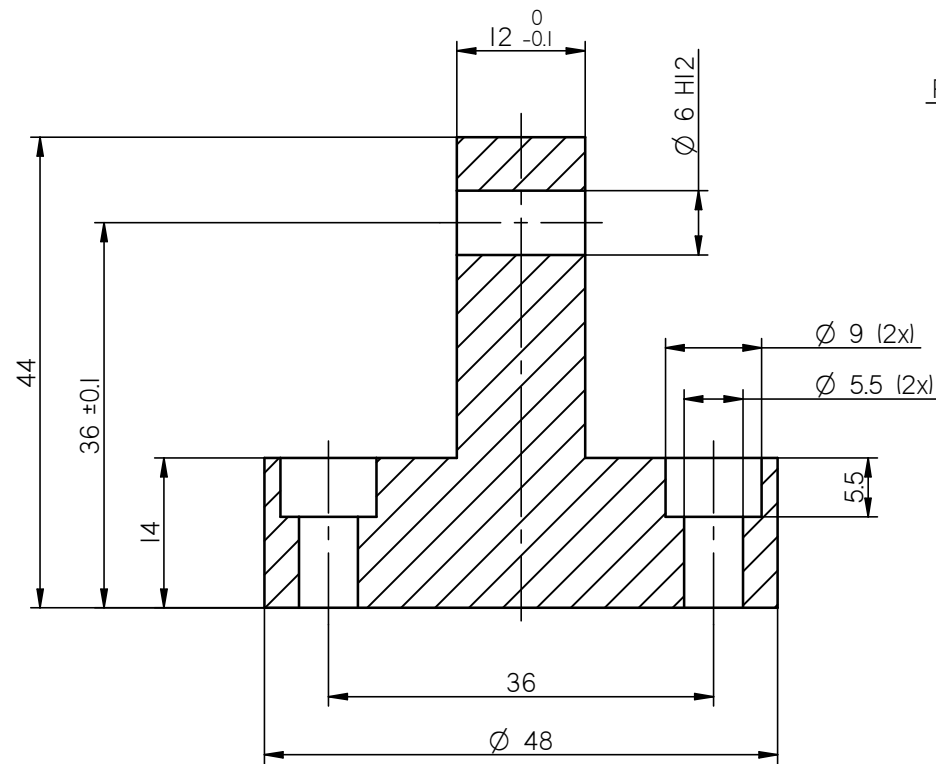

Skarpa kanter bryts 0.5x45°

Pos nr	Antal	Titel/Benämning, beteckning, material, dimension o d			Artikel nr/referens	
Konstruerad UK	Granskad av PF	Godkänd av - datum PT 201015	Generell tolerans ISO 2768-1f	Standard A4	Vyplacering E	Skala 1:2
Agare		KUNGSMADESKOLAN		Benämning FRÄS 2		Datum 201005
					Ritningsnummer	29

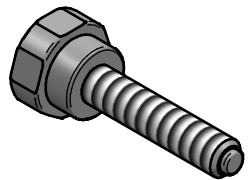
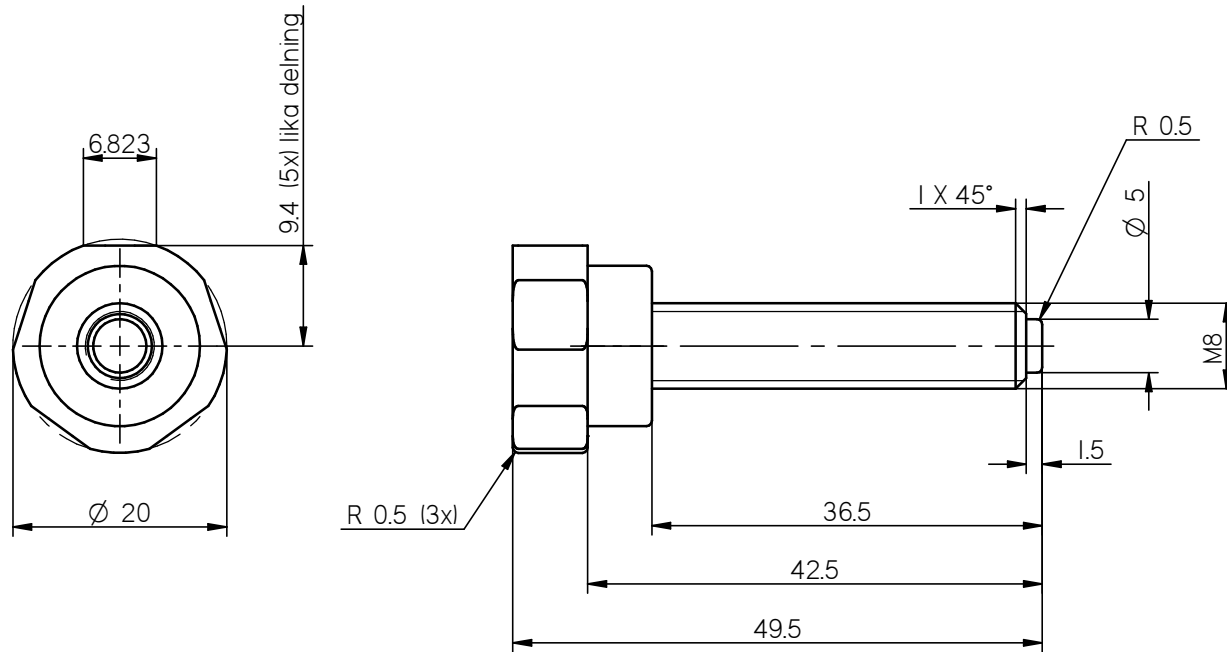

Skarpa kanter bryts 0.5x45°

Pos nr	Antal	Titel/Benämning, beteckning, material, dimension o d			Artikel nr/referens	
Konstruerad UK	Granskad av PF	Godkänd av - datum PT 201015	Generell tolerans ISO 2768-1f	Standard A4	Vyplacering E	Skala 1:2
Agare		KUNGSMADESKOLAN		Benämning SVARV 1		Datum 201005
					Ritningsnummer	8

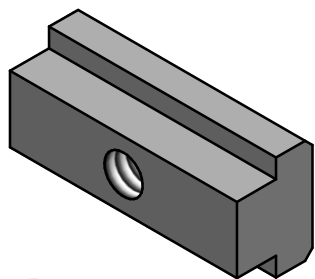
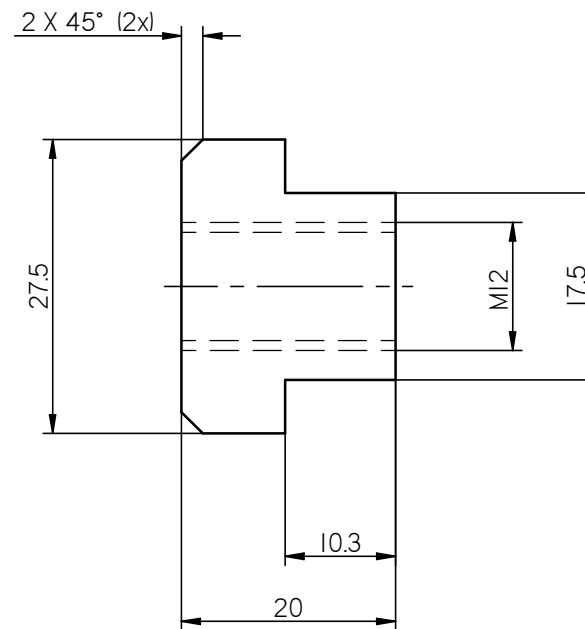
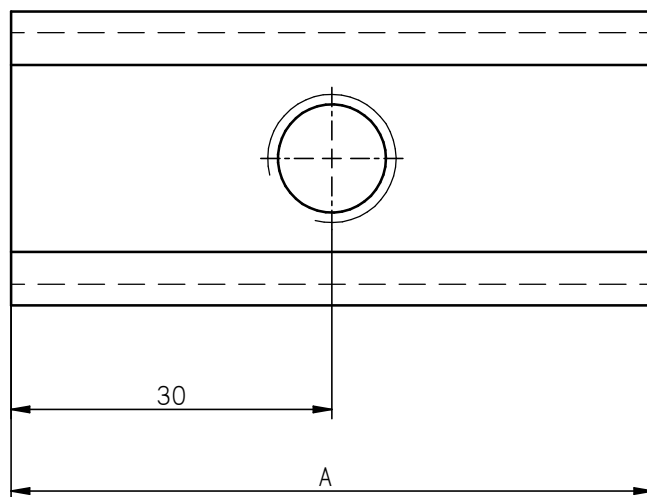

A	
30	
60	
90	

Skarpa kanter bryts 0.5x45°

Pos nr	Antal	Titel/Benämning, beteckning, material, dimension o d			Artikel nr/referens	
Konstruerad UK	Granskad av PF	Godkänd av - datum PT 201015	Generell tolerans ISO 2768-1f	Standard A4	Vyplacering E	Skala 1:2
Agare		KUNGSMADESKOLAN		Benämning FRÄS 1		Datum 201005
					Ritningsnummer	9

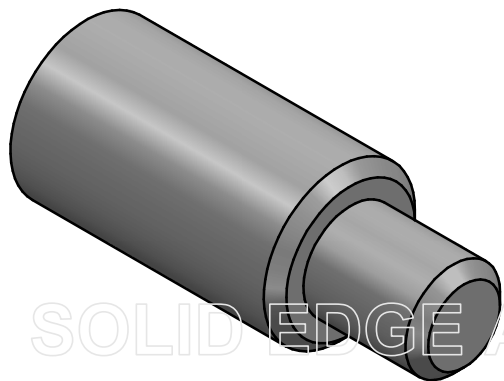
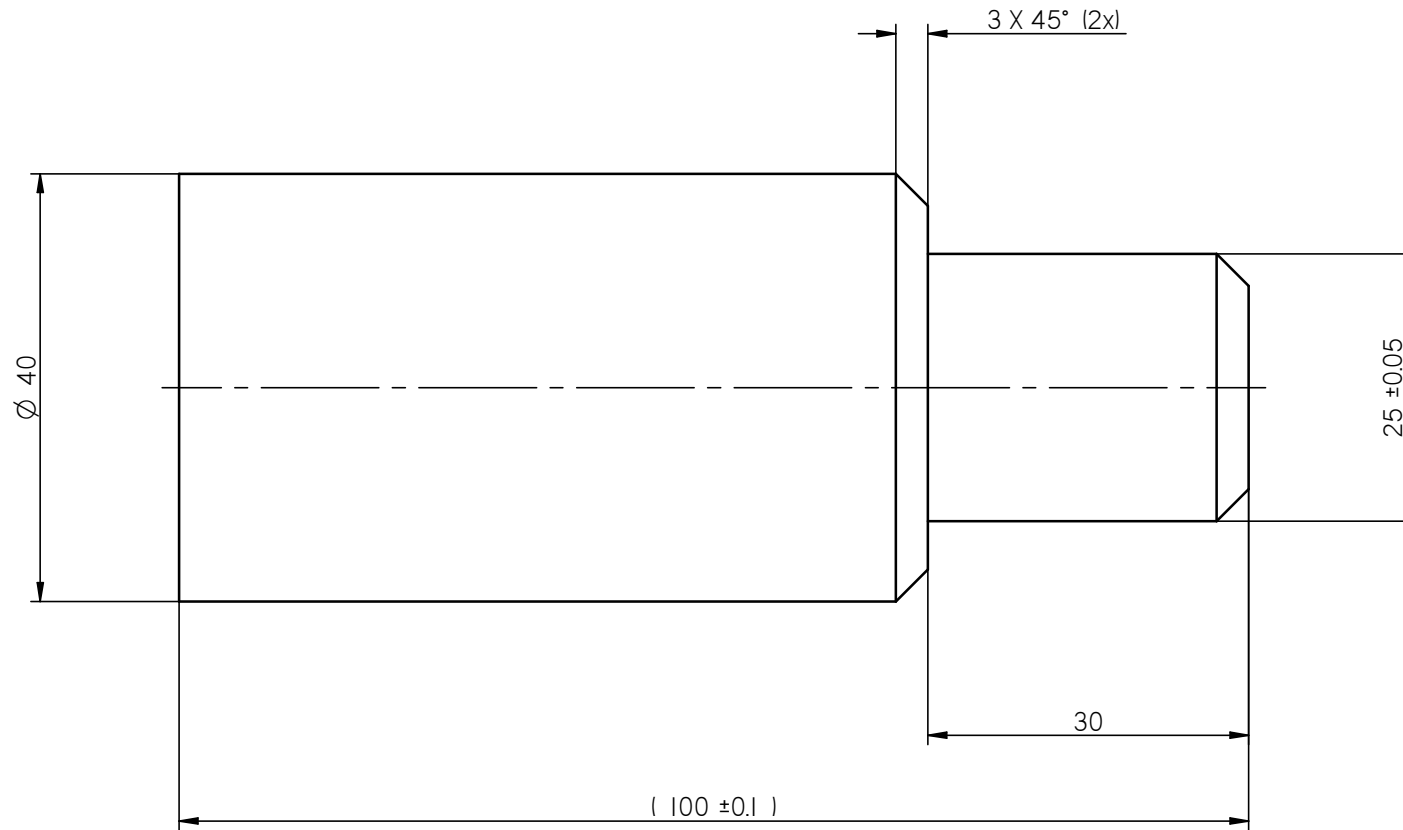

Skarpa kanter bryts $0.5 \times 45^\circ$

Pos nr	Antal	Titel/Benämning, beteckning, material, dimension o d			Artikel nr/referens	
Konstruerad UK	Granskad av PF	Godkänd av - datum PT 201015	Generell tolerans ISO 2768-1f	Standard A4	Vyplacering E	Skala 1:2
Agare		KUNGSMADESKOLAN		Benämning SVARV 1		Datum 201005
					Ritningsnummer	1

SOLID EDGE ACADEMIC COPY

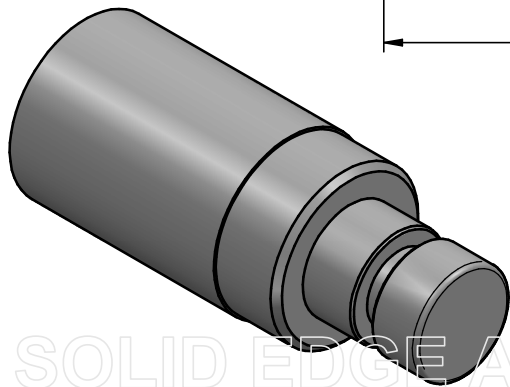
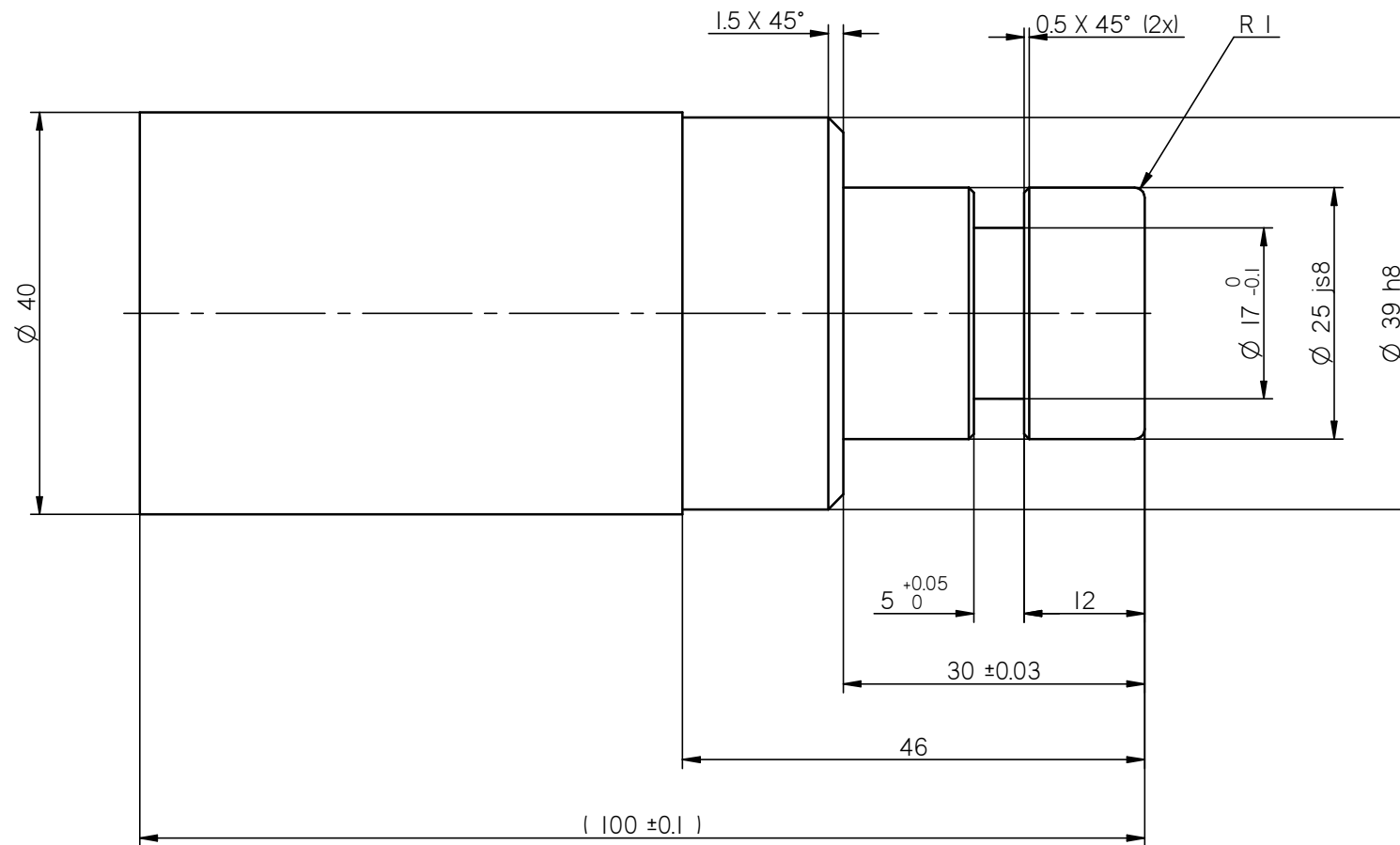

Skarpa kanter bryts $0.5 \times 45^\circ$

Pos nr	Antal	Titel/Benämning, beteckning, material, dimension o d			Artikel nr/referens	
Konstruerad UK	Granskad av PF	Godkänd av - datum PT 201015	Generell tolerans ISO 2768-1f	Standard A4	Vyplacering E	Skala 1:2
Agare		KUNGSMADESKOLAN		Benämning SVARV 1		Datum 201005
					Ritningsnummer	3

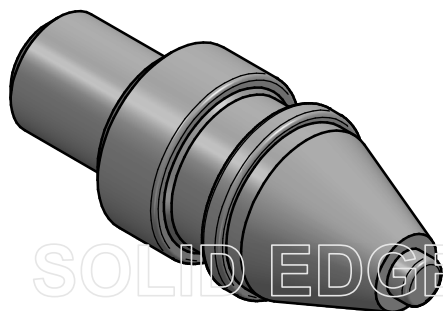
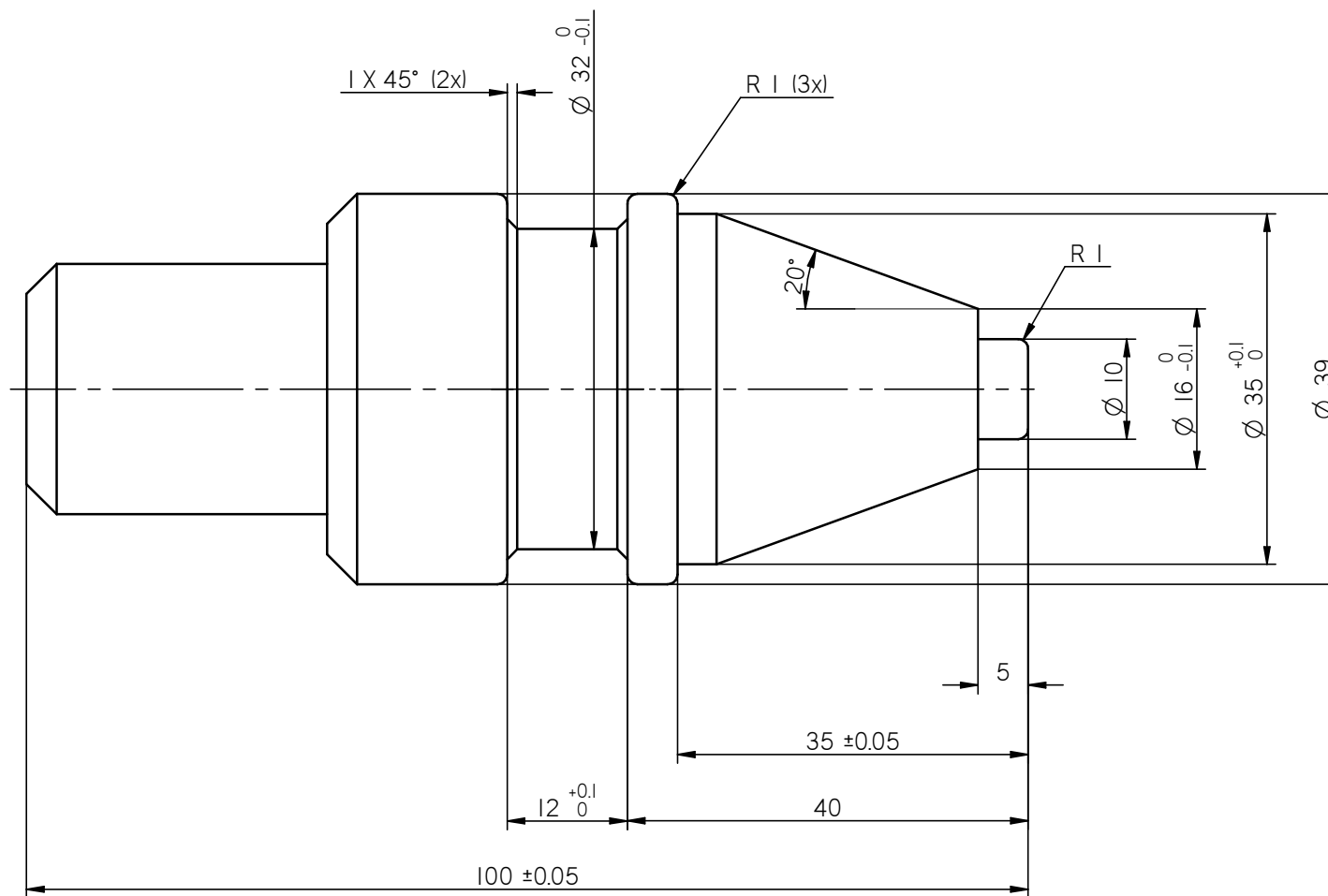

Skarpa kanter bryts $0.5 \times 45^\circ$

Pos nr	Antal	Titel/Benämning, beteckning, material, dimension o d			Artikel nr/referens	
Konstruerad UK	Granskad av PF	Godkänd av - datum PT 201015	Generell tolerans ISO 2768-1f	Standard A4	Vyplacering E	Skala 1:2
Agare		KUNGSMADESKOLAN		Benämning SVARV 1		Datum 201005
					Ritningsnummer	4

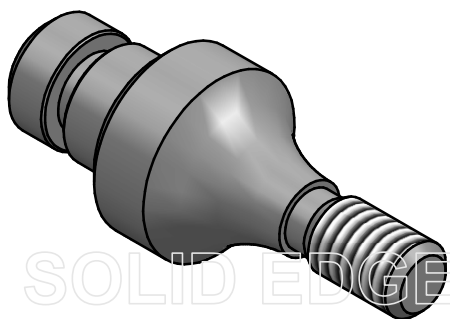
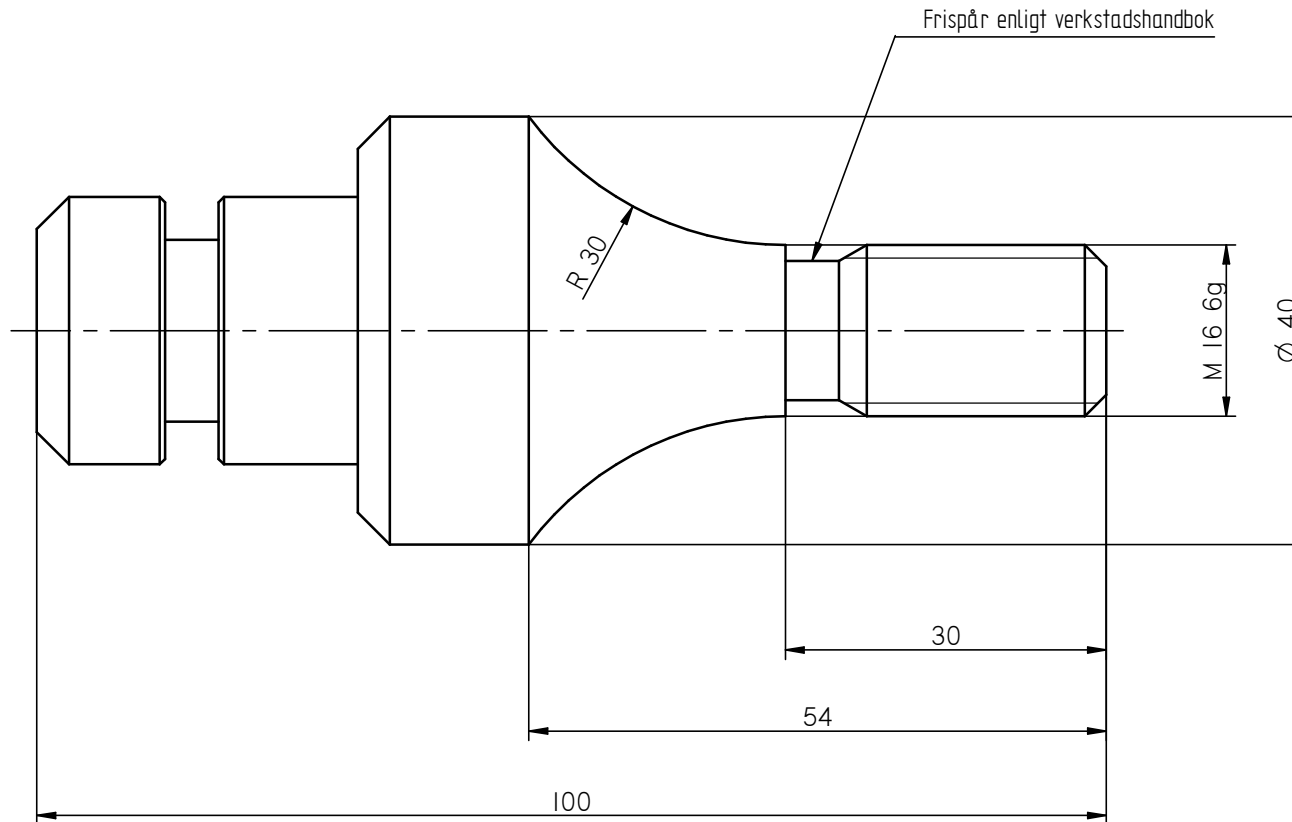

Skarpa kanter bryts $0.5 \times 45^\circ$

Pos nr	Antal	Titel/Benämning, beteckning, material, dimension o d			Artikel nr/referens	
Konstruerad UK	Granskad av PF	Godkänd av - datum PT 201015	Generell tolerans ISO 2768-1f	Standard A4	Vyplacering E	Skala 1:2
Agare		KUNGSMADESKOLAN		Benämning SVARV 1		Datum 201005
					Ritningsnummer	7

SOLID EDGE ACADEMIC COPY

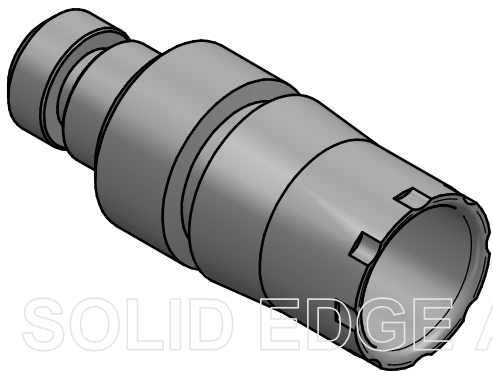
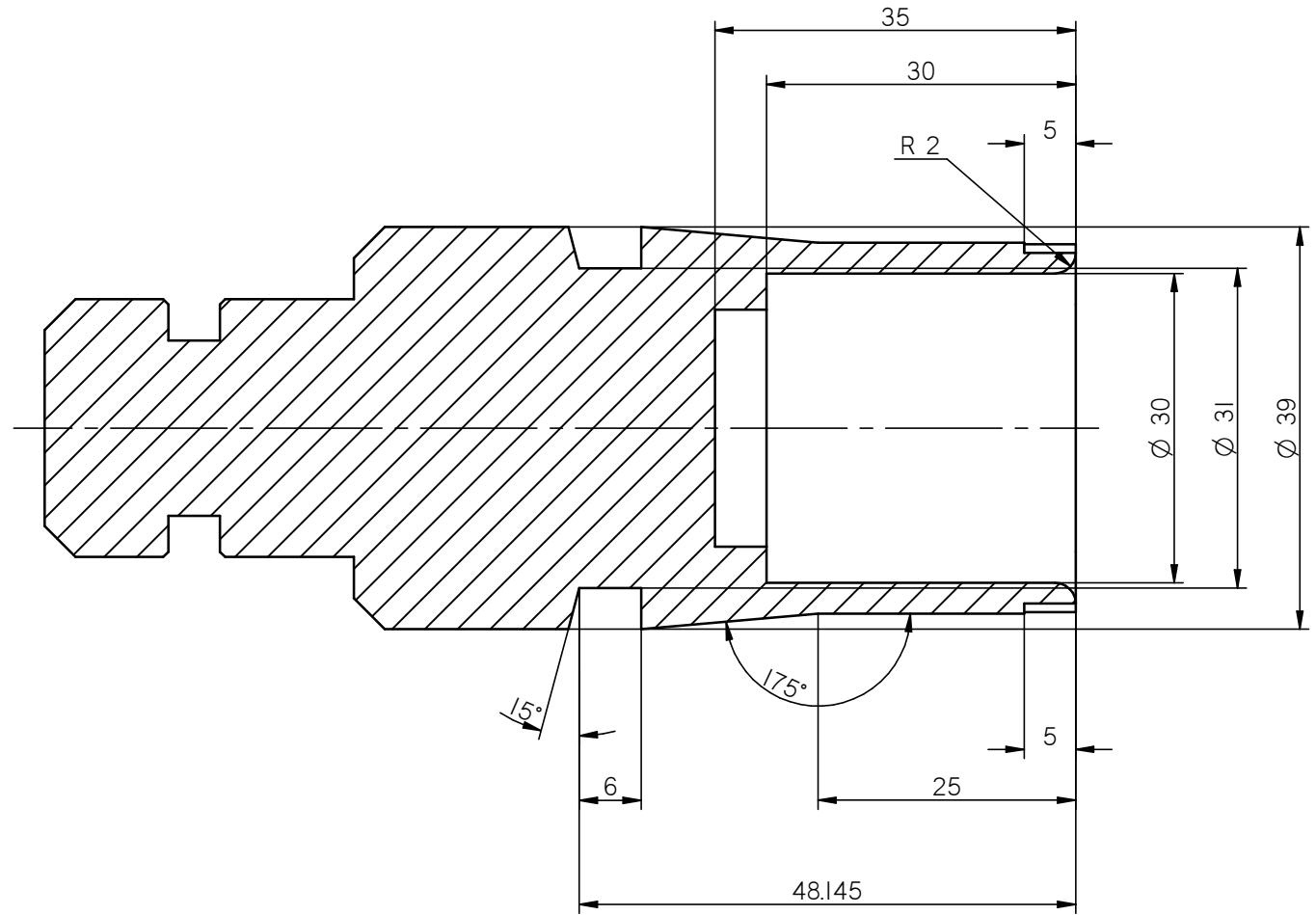
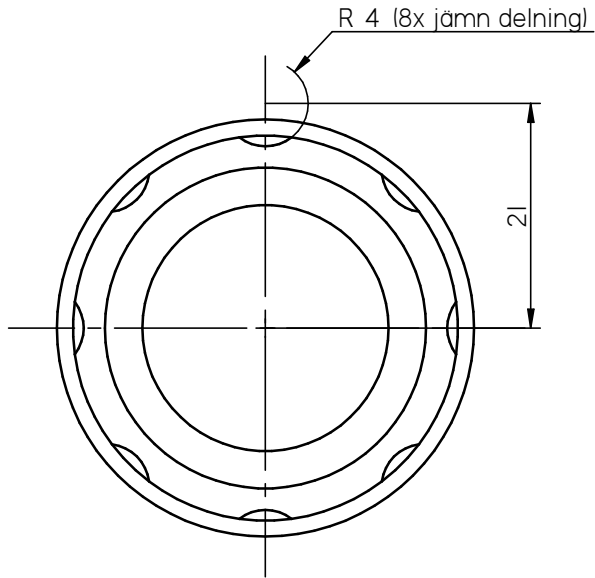

Skarpa kanter bryts 0.5x45°

Pos nr	Antal	Titel/Benämning, beteckning, material, dimension o d			Artikel nr/referens	
Konstruerad UK	Granskad av PF	Godkänd av - datum PT 201015	Generell tolerans ISO 2768-1f	Standard A4	Vyplacering E	Skala 1:2
Agare		Benämning		Datum 201005		
KUNGSMADESKOLAN		SVARV 2		Ritningsnummer 27		

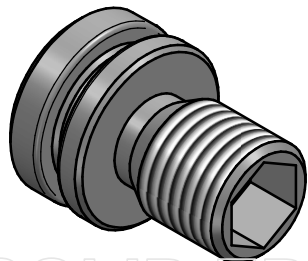
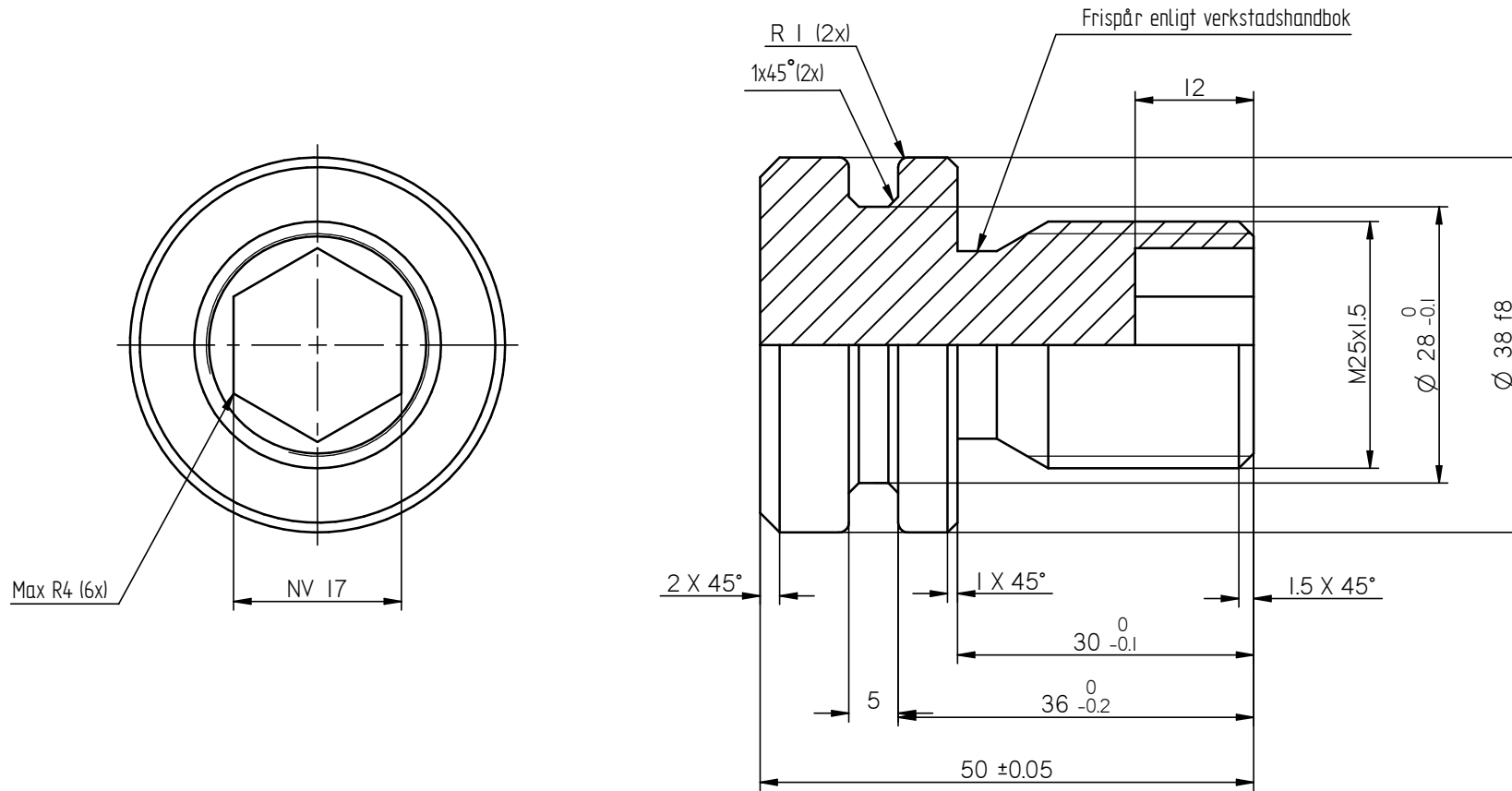

Skarpa kanter bryts $0.5 \times 45^\circ$

Pos nr	Antal	Titel/Benämning, beteckning, material, dimension o d			Artikel nr/referens	
Konstruerad UK	Granskad av PF	Godkänd av - datum PT 201015	Generell tolerans ISO 2768-1f	Standard A4	Vyplacering E	Skala 1:2
Agare:  KUNGSMADESKOLAN					Benämning SVARV 2 MÄT 2	
					Ritningsnummer	Datum 201005 25

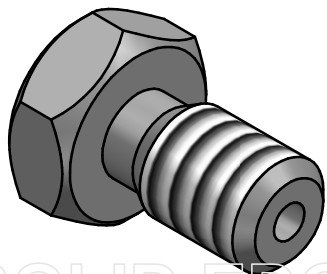
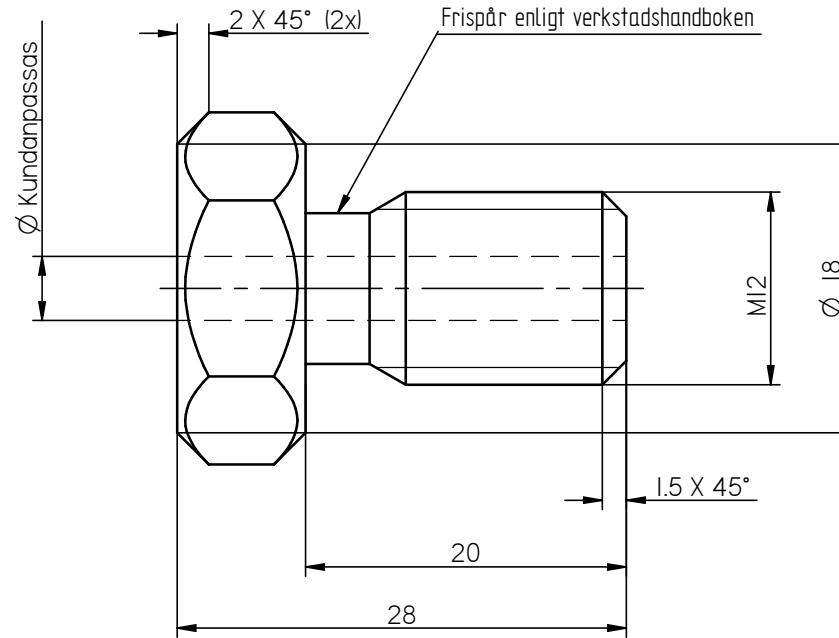
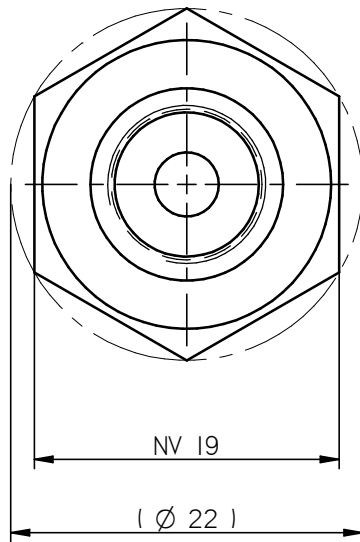

Skarpa kanter bryts 0.5x45°

Pos nr	Antal	Titel/Benämning, beteckning, material, dimension o d			Artikel nr/referens	
Konstruerad UK	Granskad av PF	Godkänd av - datum PT 201015	Generell tolerans ISO 2768-1f	Standard A4	Vyplacering E	Skala 1:2
Agare		KUNGSMADESKOLAN		Benämning SVARV 2		Datum 201005
					Ritningsnummer	21

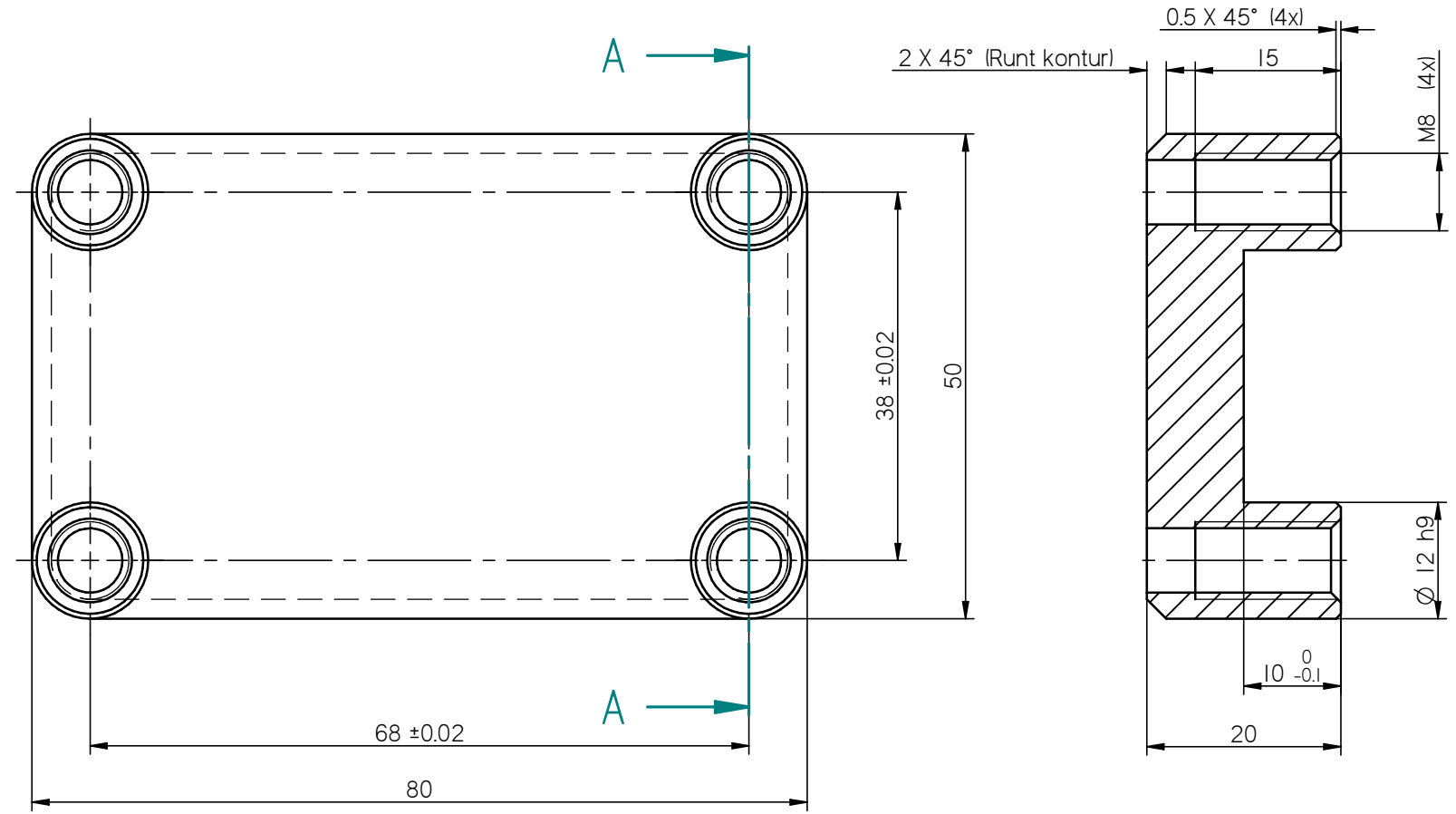

SNITT A-A

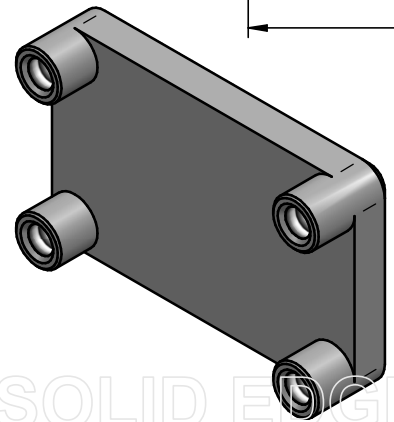

Skarpa kanter bryts 0.5x45°

Pos nr	Antal	Titel/Benämning, beteckning, material, dimension o d			Artikel nr/referens	
Konstruerad UK	Granskad av PF	Godkänd av - datum PT 201015	Generell tolerans ISO 2768-1f	Standard A4	Vyplacering E	Skala 1:2
Agare			Benämning FRÄS 1		Datum 201005	Ritningsnummer 12

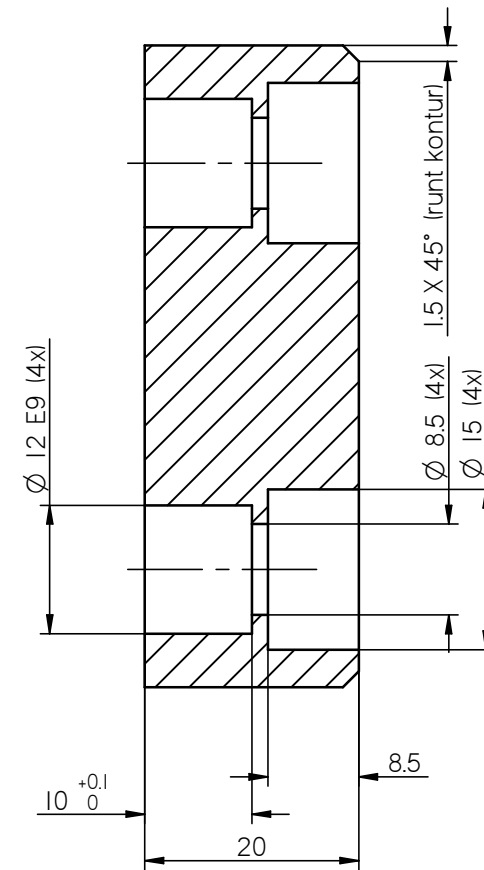
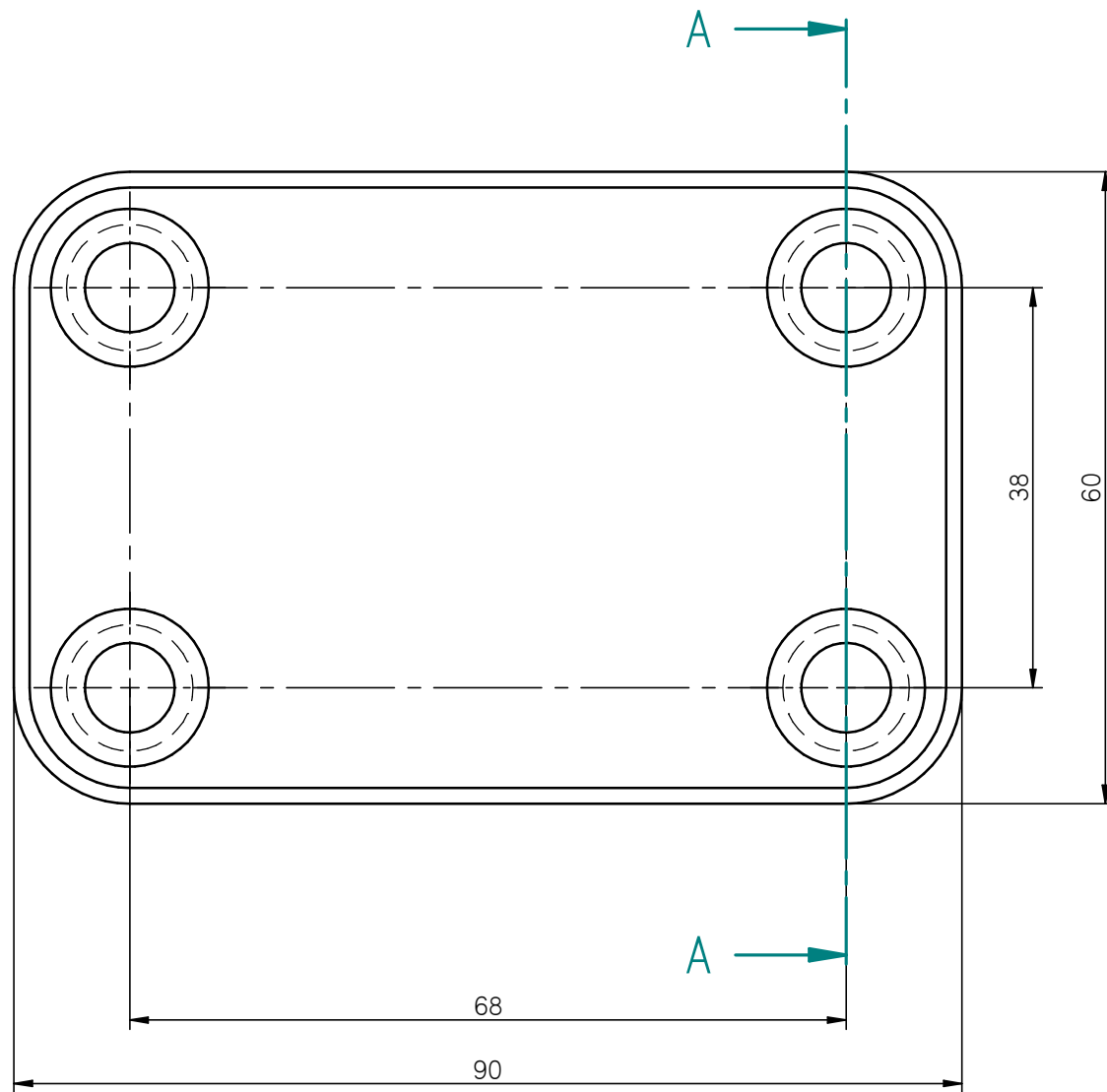

SNITT A-A

Skarpa kanter bryts 0.5x45°

Pos nr	Antal	Titel/Benämning, beteckning, material, dimension o d			Artikel nr/referens	
Konstruerad UK	Granskad av PF	Godkänd av - datum PT 201015	Generell tolerans ISO 2768-1f	Standard A4	Vyplacering E	Skala 1:2
Agare		KUNGSMADESKOLAN		Benämning FRÄS 1		Datum 201005
					Ritningsnummer	11

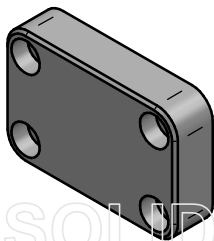

SNITT A-A

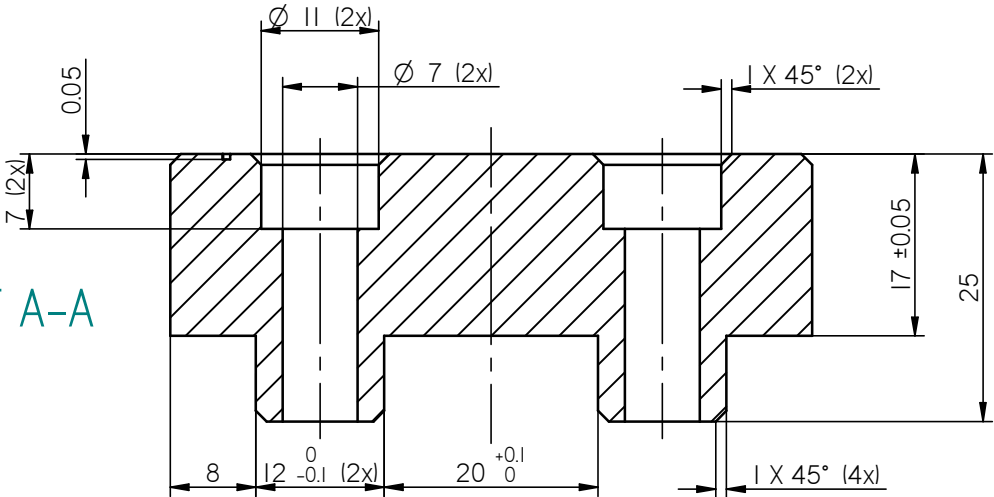

SNITT B-B

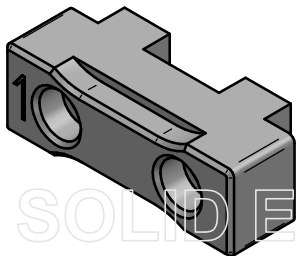
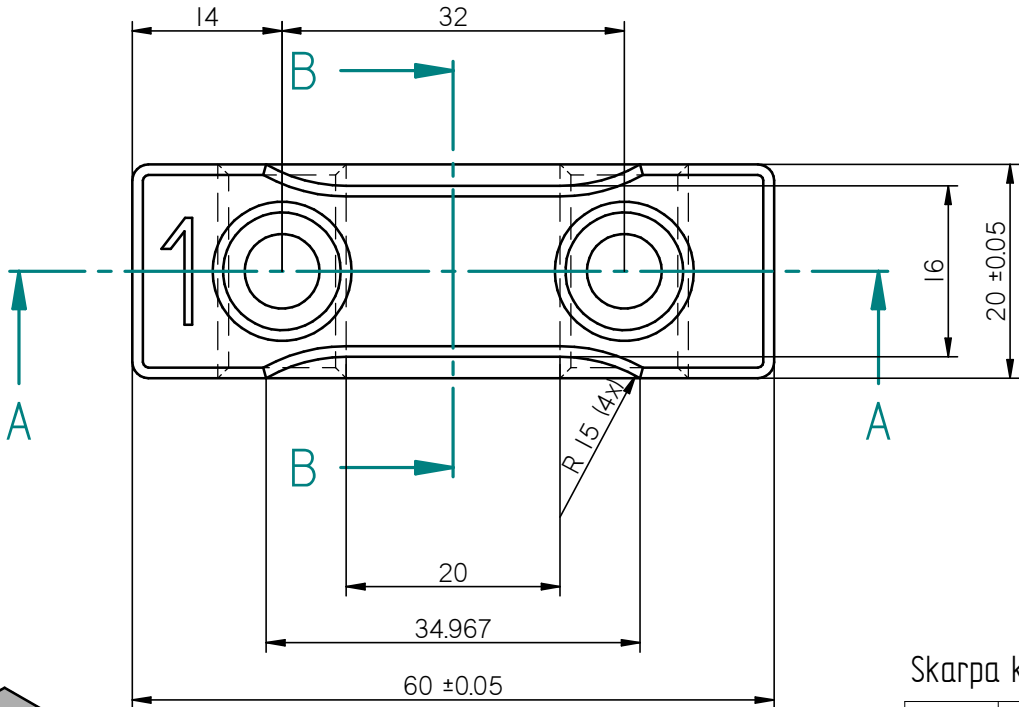
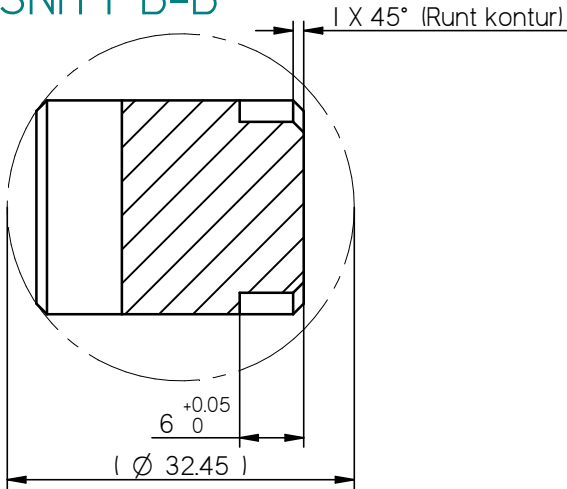

Skarpa kanter bryts 0.5x45°

Pos nr	Antal	Titel/Benämning, beteckning, material, dimension o d			Artikel nr/referens	
Konstruerad UK	Granskad av PF	Godkänd av - datum PT 201015	Generell tolerans ISO 2768-1f	Standard A4	Vyplacering E	Skala 1:2
Agare		KUNGSMADESKOLAN		Benämning FRÄS 1 MÄT 3		Datum 201005
Ritningsnummer						10

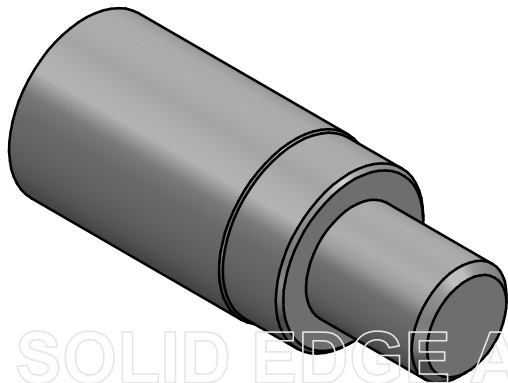
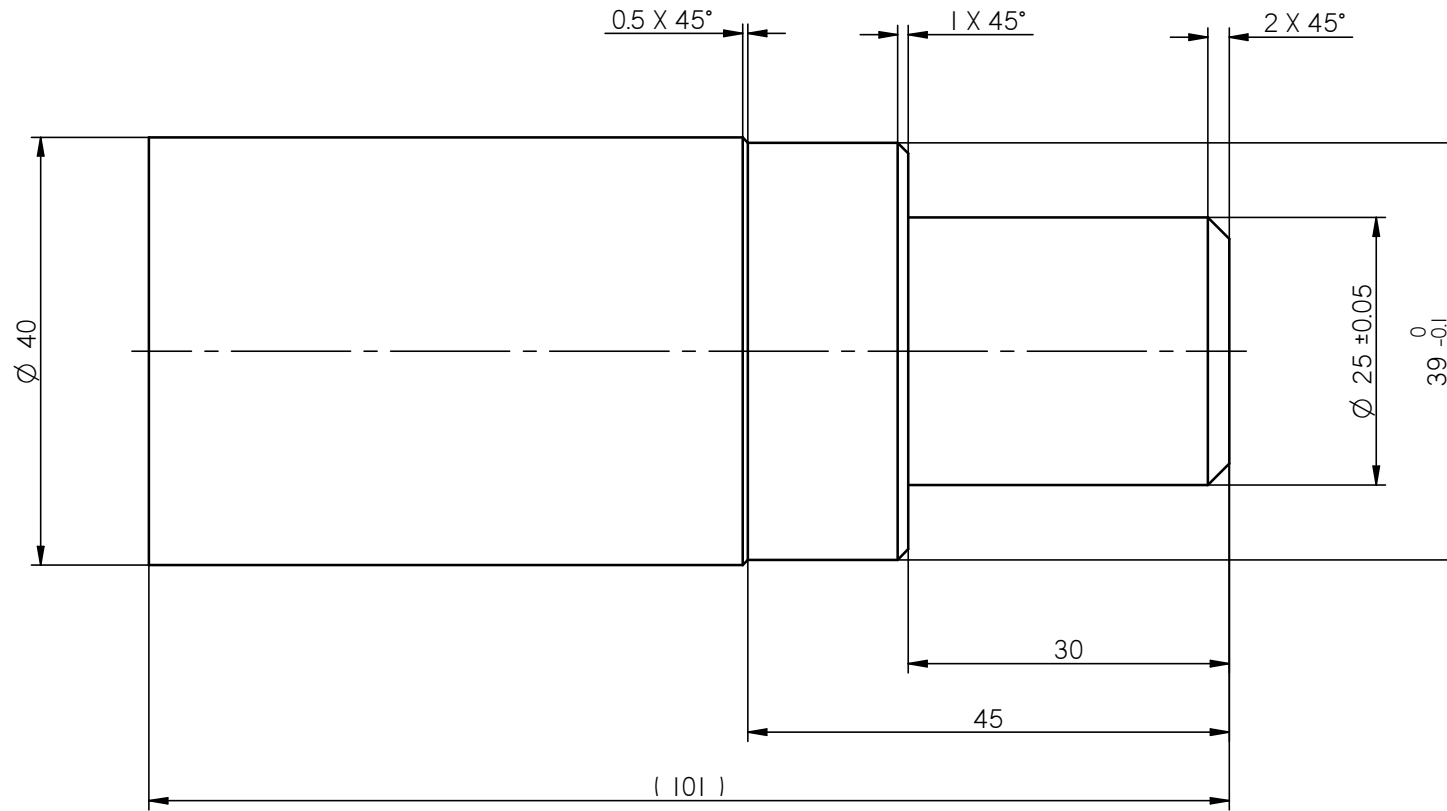

Skarpa kanter bryts $0.5 \times 45^\circ$

Pos nr	Antal	Titel/Benämning, beteckning, material, dimension o d			Artikel nr/referens	
Konstruerad UK	Granskad av PF	Godkänd av - datum PT 201015	Generell tolerans ISO 2768-1f	Standard A4	Vyplacering E	Skala 1:2
Agare		KUNGSMADESKOLAN		Benämning SVARV 1		Datum 201005
					Ritningsnummer	2

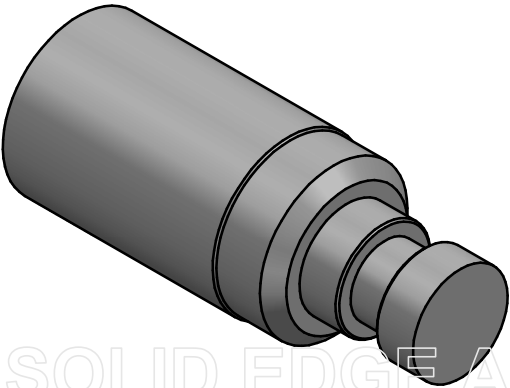
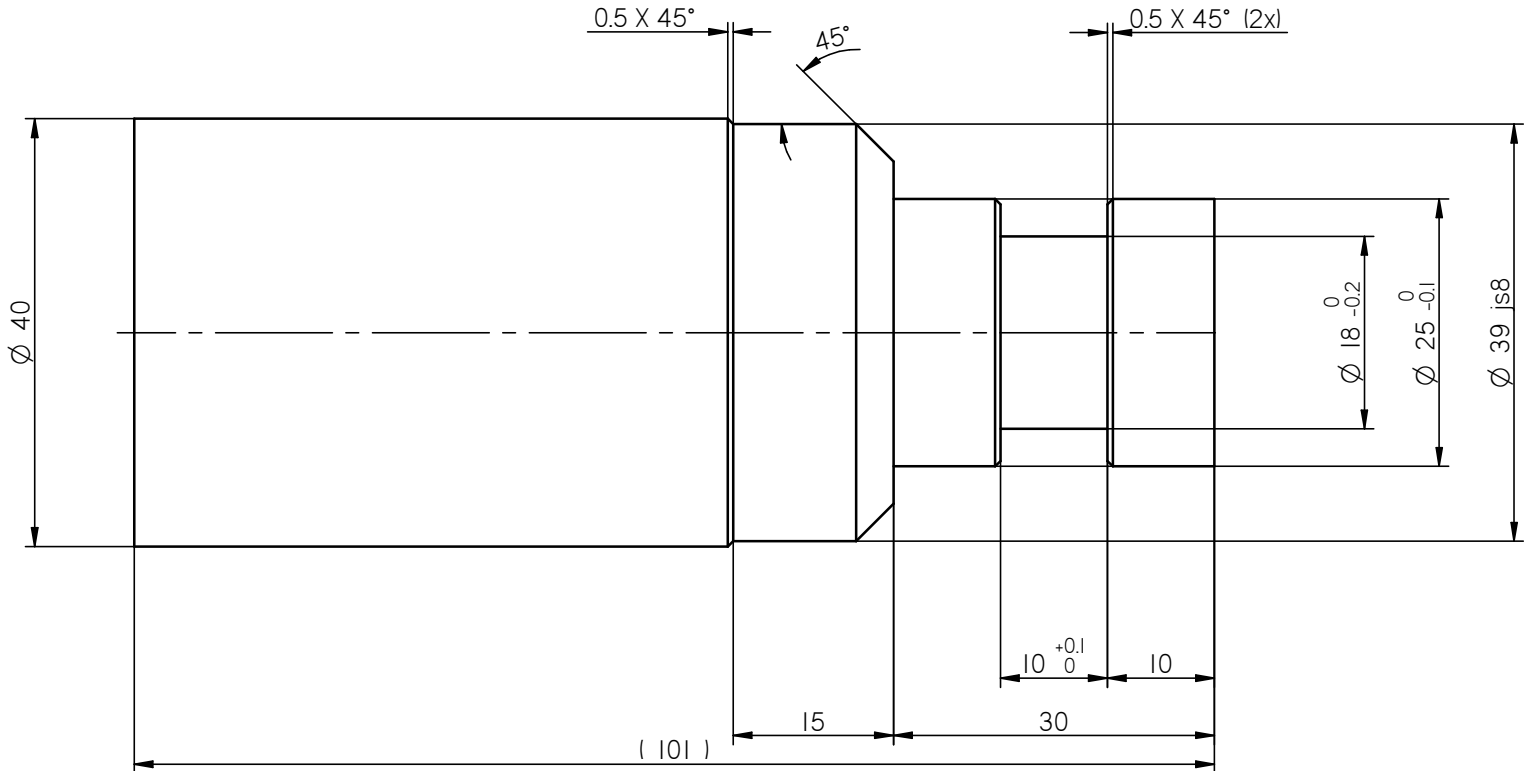

SOLID EDGE ACADEMIC COPY

Skarpa kanter bryts 0.5x45°

Pos nr	Antal	Titel/Benämning, beteckning, material, dimension o d			Artikel nr/referens	
Konstruerad UK	Granskad av PF	Godkänd av - datum PT 201015	Generell tolerans ISO 2768-1f	Standard A4	Vyplacering E	Skala 1:2
Agare		KUNGSMADESKOLAN		Benämning SVARV 1		Datum 201005
					Ritningsnummer	3

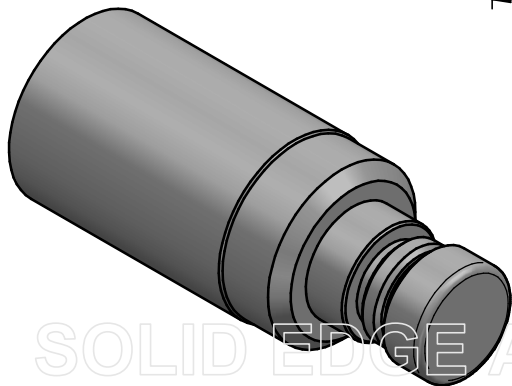
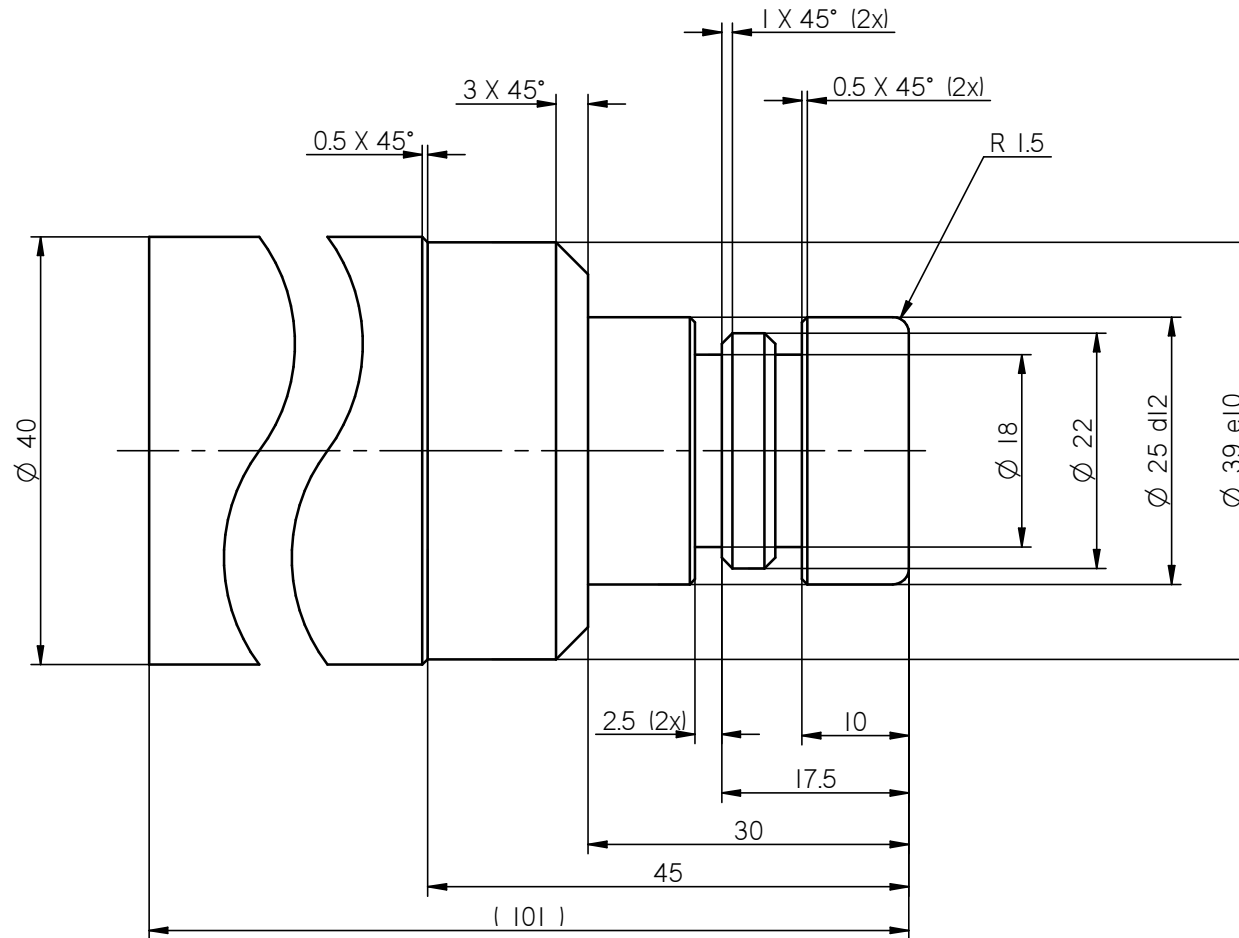

Skarpa kanter bryts $0.5 \times 45^\circ$

Pos nr	Antal	Titel/Benämning, beteckning, material, dimension o d			Artikel nr/referens	
Konstruerad UK	Granskad av PF	Godkänd av - datum PT 201015	Generell tolerans ISO 2768-1f	Standard A4	Vyplacering E	Skala 1:2
Agare		KUNGSMADESKOLAN		Benämning SVARV 1		Datum 201005
					Ritningsnummer	5

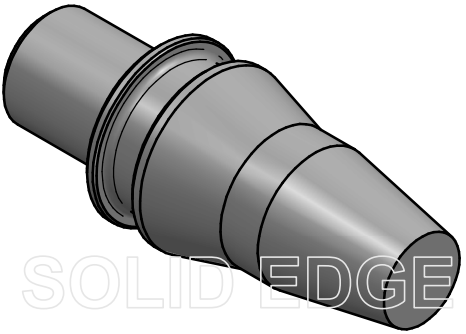
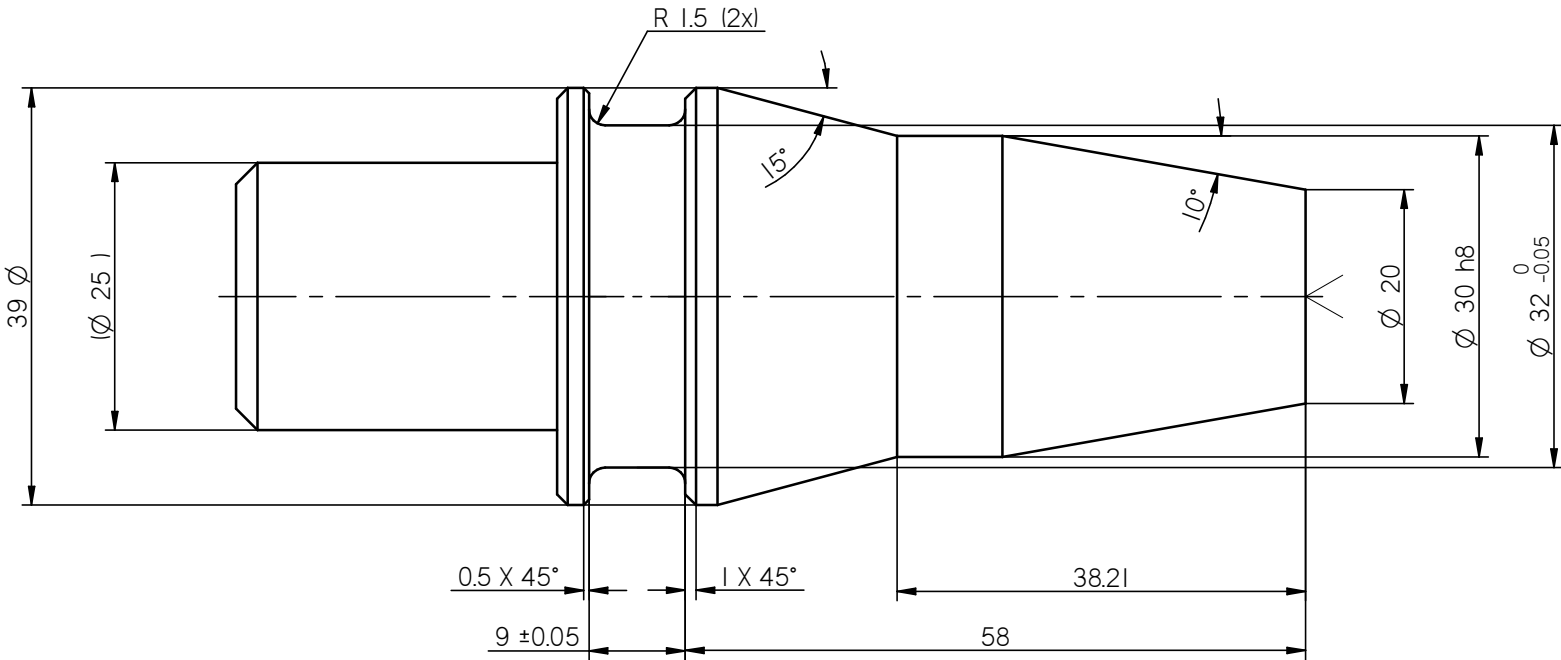

Skarpa kanter bryts 0.5x45°

SOLID EDGE ACADEMIC COPY

Pos nr	Antal	Titel/Benämning, beteckning, material, dimension o d			Artikel nr/referens	
Konstruerad UK	Granskad av PF	Godkänd av - datum PT 201015	Generell tolerans ISO 2768-1f	Standard A4	Vyplacering E	Skala 1:2
Agare		KUNGSMADESKOLAN		Benämning SVARV 1		Datum 201005
					Ritningsnummer	6

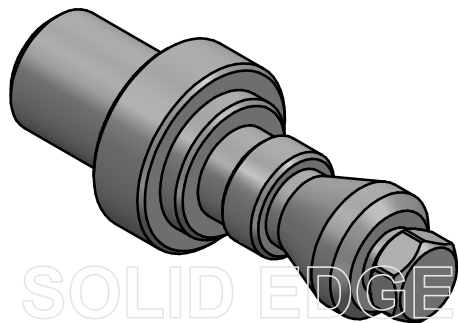
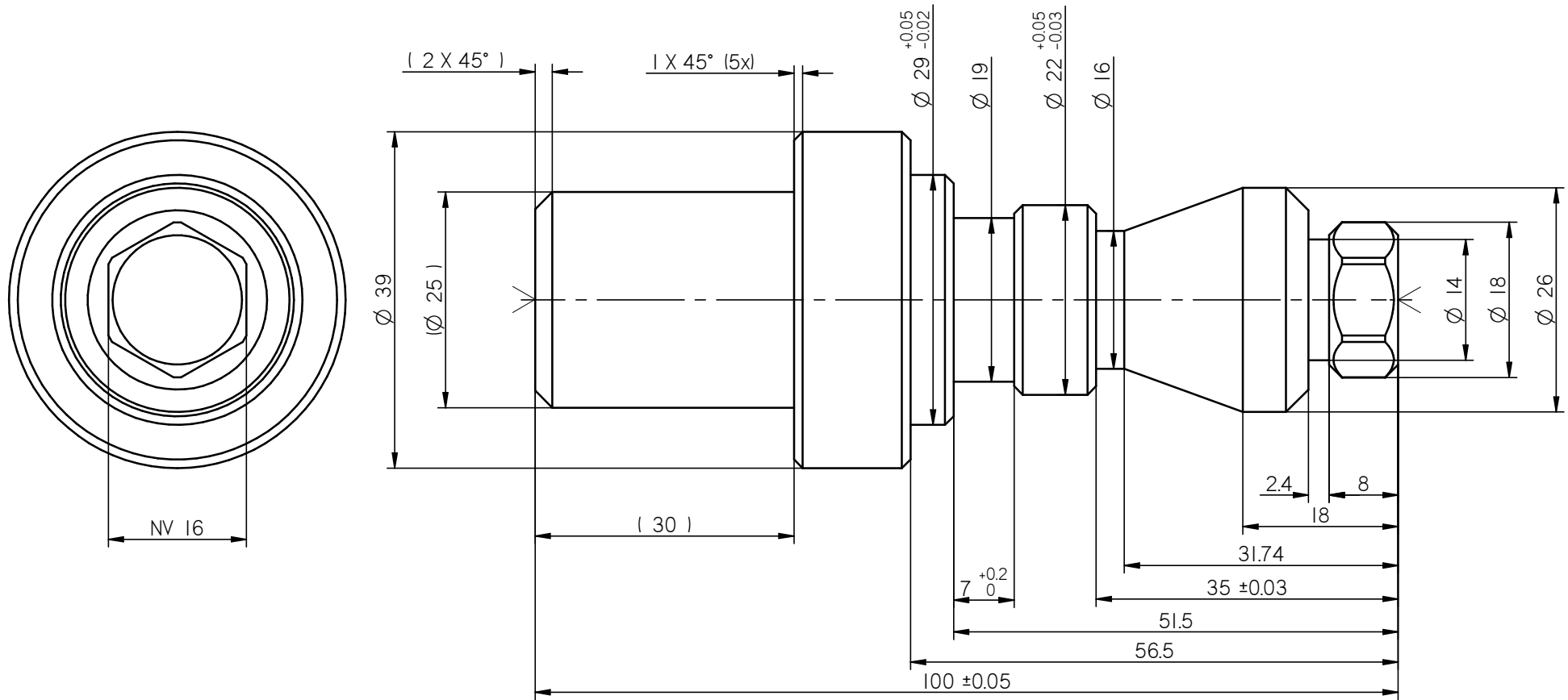

Skarpa kanter bryts 0.5x45°

Pos nr	Antal	Titel/Benämning, beteckning, material, dimension o d			Artikel nr/referens	
Konstruerad UK	Granskad av PF	Godkänd av - datum PT 201015	Generell tolerans ISO 2768-1f	Standard A4	Vyplacering E	Skala 1:2
Agare		KUNGSMADESKOLAN		Benämning SVARV 2		Datum 201005
					Ritningsnummer	23

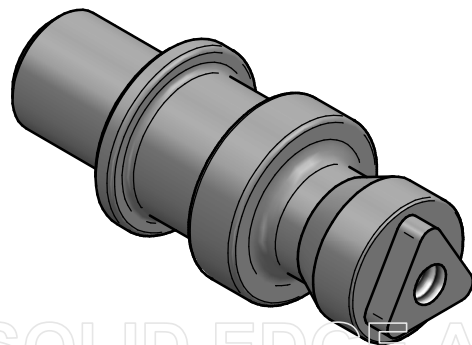
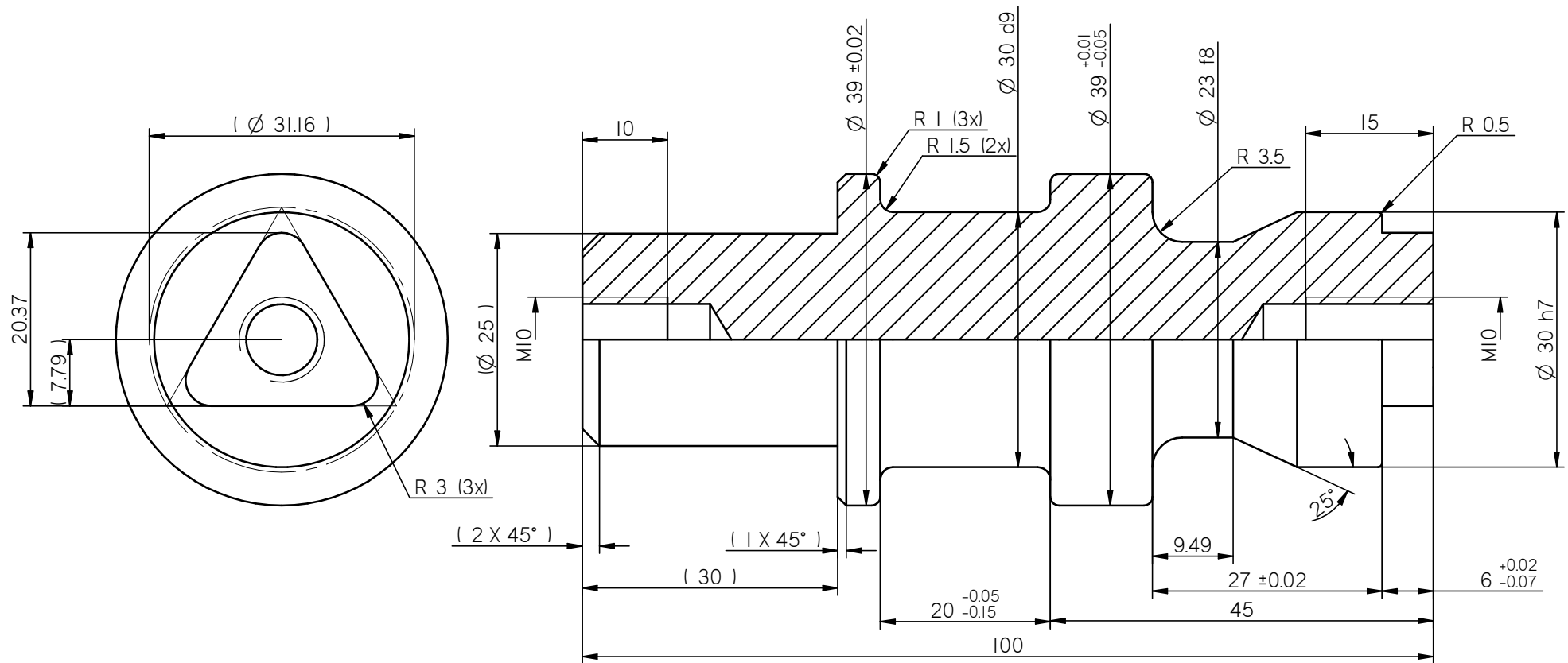

Skarpa kanter bryts 0.5x45°

Pos nr	Antal	Titel/Benämning, beteckning, material, dimension o d			Artikel nr/referens	
Konstruerad UK	Granskad av PF	Godkänd av - datum PT 201015	Generell tolerans ISO 2768-1f	Standard A4	Vyplacering E	Skala 1:2
Agare		KUNGSMADESKOLAN		Benämning SVARV 2		Datum 201005
					Ritningsnummer	24

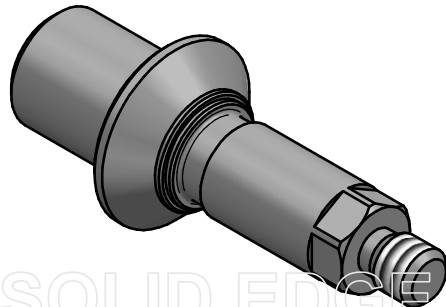
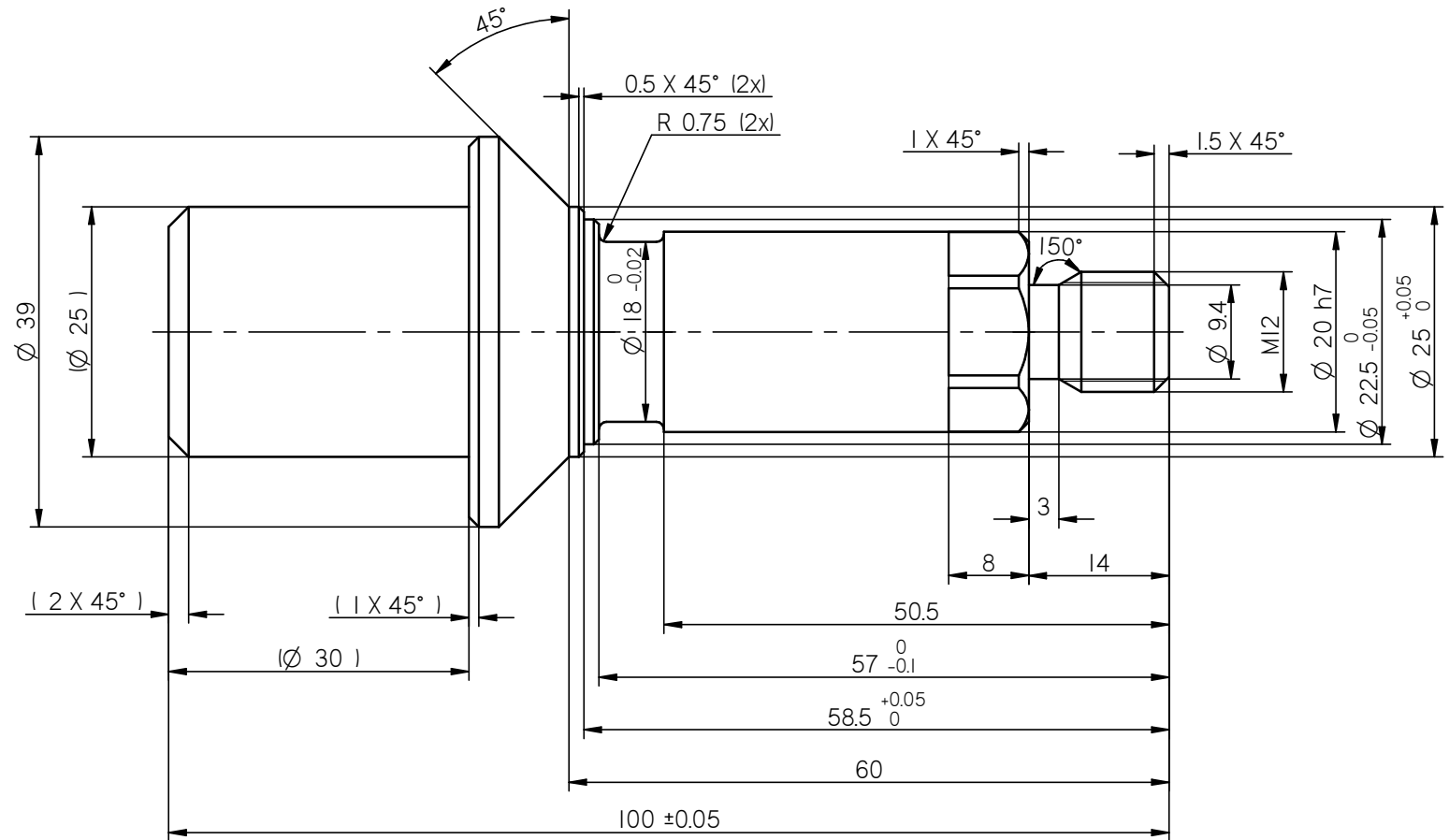
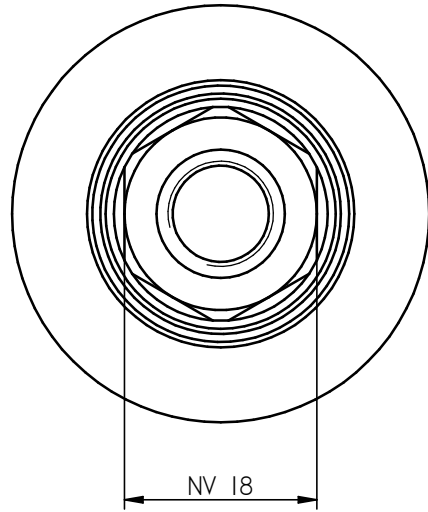

Skarpa kanter bryts 0.5x45°

Pos nr	Antal	Titel/Benämning, beteckning, material, dimension o d			Artikel nr/referens	
Konstruerad UK	Granskad av PF	Godkänd av - datum PT 201015	Generell tolerans ISO 2768-1f	Standard A4	Vyplacering E	Skala 1:2
Agare		Benämning		Datum 201005		
KUNGSMADESKOLAN		SVARV 2		Ritningsnummer 22		

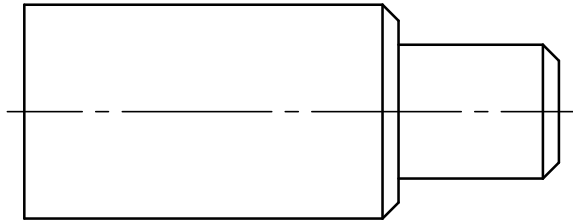

1

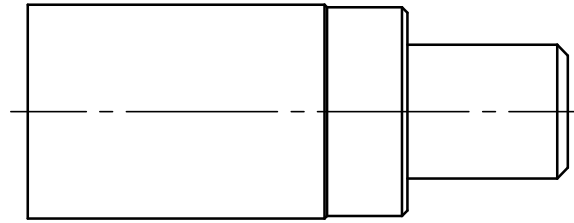

2

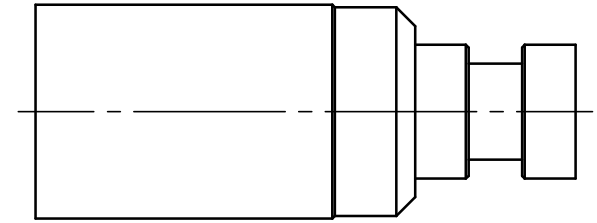

3

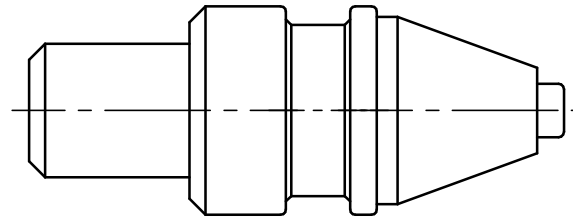

4

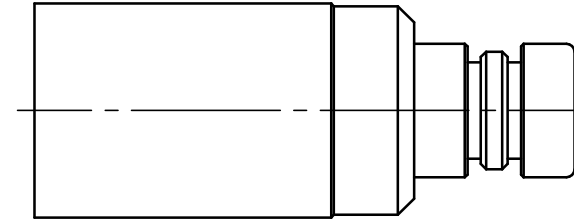

5

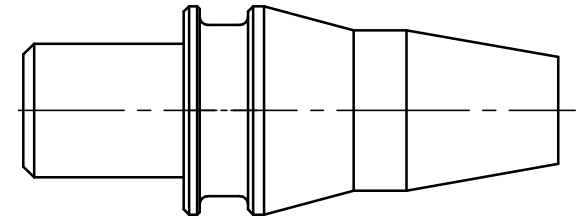

6

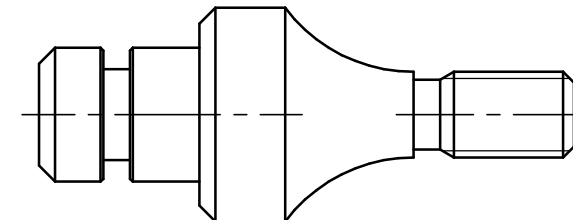

7

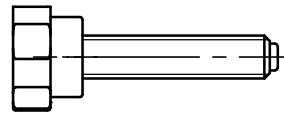

8

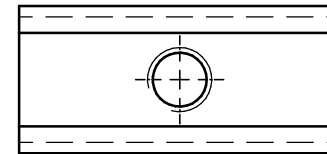

9

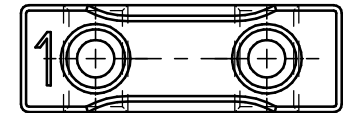

10

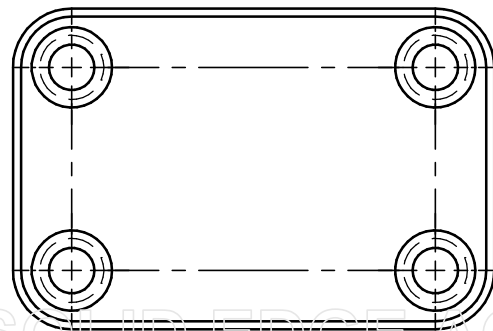

11

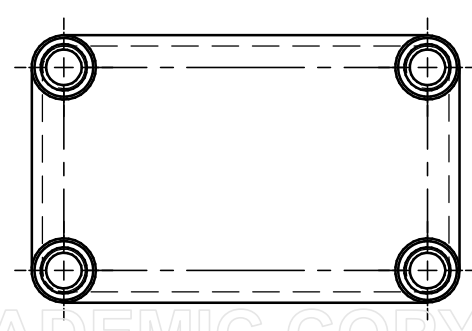

12

Skarpa kanter bryts 0.5x45°

Pos nr	Antal	Titel/Benämning, beteckning, material, dimension o d			Artikel nr/referens	
Konstruerad UK	Granskad av PF	Godkänd av - datum PT 201015	Generell tolerans ISO 2768-1f	Standard A4	Vyplacering E	Skala 1:2
Agare		Benämning		Datum 201005		
KUNGSMADESKOLAN		Datorstyrd produktion 1				
Ritningsnummer						

SOLID EDGE ACADEMIC COPY

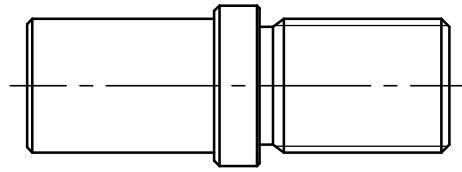

20

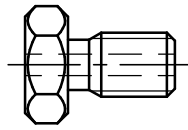

21

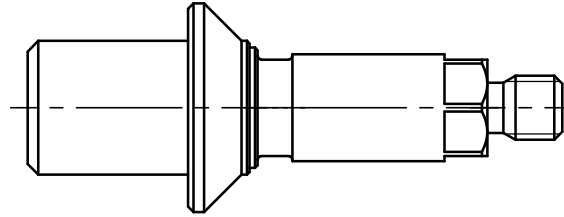

22

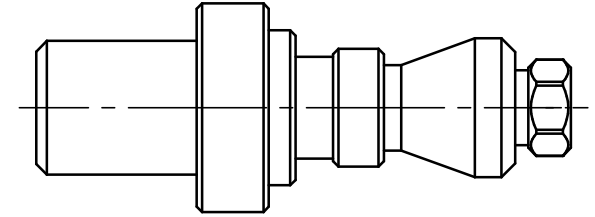

23

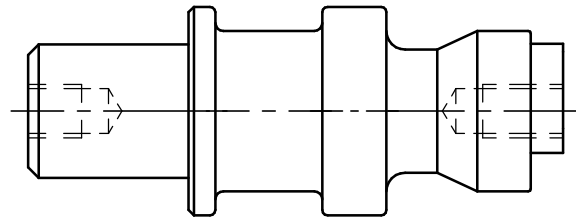

24

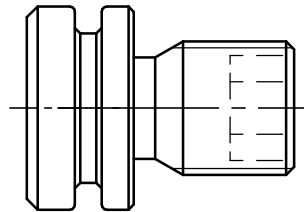

25



26

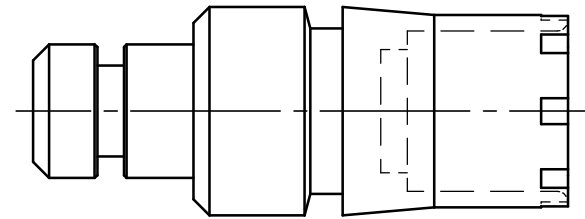

27



28

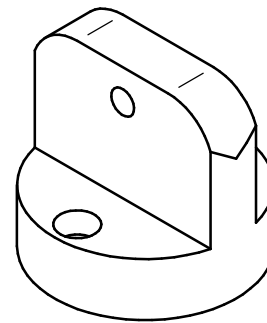

29

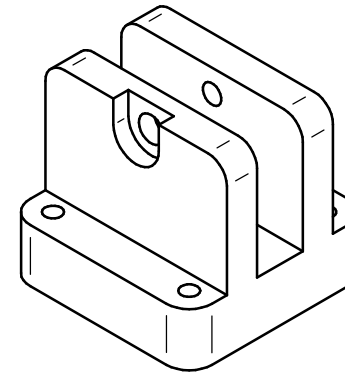

30

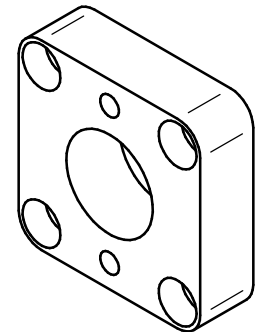

31

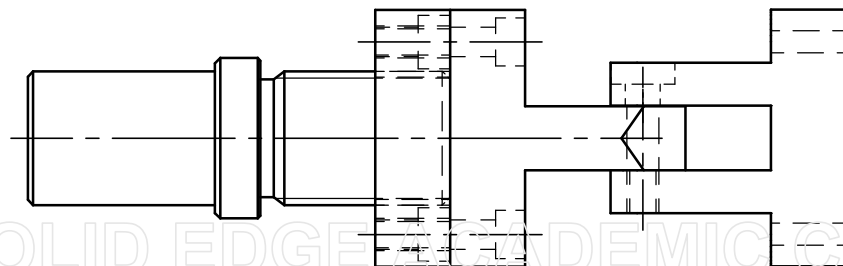

20

31

29

30

Skarpa kanter bryts 0.5x45°

Pos nr	Antal	Titel/Benämning, beteckning, material, dimension o d			Artikel nr/referens	
Konstruerad UK	Granskad av PF	Godkänd av - datum PT 201015	Generell tolerans ISO 2768-1f	Standard A4	Vyplacering E	Skala 1:2
Agare				Benämning		Datum 201005
				Datorstyrd produktion 2		Ritningsnummer

SOLID EDGE ACADEMIC COPY